



SEPARATING PEOPLE FROM HAZARDS

# Safe Steelwork Connections



- STEELWORK CLAMPS, CAVITY FIXINGS, STEEL FLOOR FIXINGS & BUILDING SERVICES FIXINGS
- NO SPECIAL TOOLS OR SKILLED LABOUR REQUIRED
- NO SITE DRILLING OR WELDING REQUIRED
- THIRD PARTY APPROVALS





A KEE SAFETY PRODUCT



A KEE SAFETY PRODUCT



The **BeamClamp®** and **BoxBolt®** range of fixings from Kee Safety is a series of products that provide a secure fixing method for structural steelwork. The fixings provide solutions for joining steel together without the need for on-site drilling or welding to give much more flexibility than traditional methods. The system provides a guaranteed connection every time without the need for on-site verification, providing the installation guidelines are correctly followed.

## Approvals

The full range has been third party approved or tested by either Lloyds Register, Deutsches Institut für Bautechnik (DIBt), TÜV or by in-house physical testing. The individual approval logos can be seen by the side of the products they relate to. All approvals and loading data within this catalogue are proven by physical testing.

## Technical Support

The **BeamClamp** and **BoxBolt** range is backed up by a technical department and experienced individuals who can provide assistance on product selection through to connection design using 2D and 3D computer aided software. We can provide you with CAD blocks to insert within project drawings and we also have a connection configurator to help design individual applications, please see more details on page 15. The products are integrated in to Tekla Structures for those structural engineers that use this package to design their steelwork.

## Features

- **Third party approvals**
- **Guaranteed Factor of Safety**
- **No special tools or skills required**
- **Hot Dip Galvanised finish**

## Benefits

- **Peace of mind for the specifier**
- **Savings in installation time and cost**
- **No on-site drilling or welding**
- **Long term corrosion resistance**

# Contents

## Markets & Applications

- [4](#) [Market Sectors](#)
- [6](#) [Applications](#)

## Hollow Section Fixings

- [9](#) [BoxBolt® Intro / Technical](#)
- [12](#) [BoxBolt® Installation](#)
- [13](#) [BoxBolt® Applications](#)

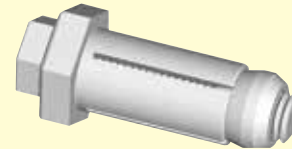

## Steel Clamping Fixings

- [14](#) [BeamClamp® Intro/Technical](#)
- [16](#) [Individual Clamps](#)
- [22](#) [Packing Pieces](#)
- [23](#) [Location Plates & Bolt Lengths](#)
- [24](#) [Rigging Clamps](#)
- [25](#) [High Friction Clamps](#)
- [28](#) [Specifying the Correct Product](#)
- [31](#) [FastFit®](#)
- [34](#) [Typical Connection Details](#)

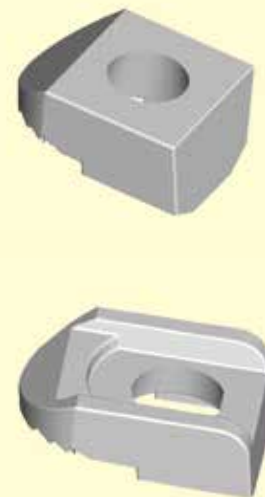

## Steel Flooring Fixings

- [37](#) [FloorFix HT & FloorFix](#)
- [40](#) [Gratefix](#)
- [41](#) [Grating Clip](#)



## Building Services Fixings

- [42](#) [Type BL](#)
- [43](#) [Types BU, BV, BX](#)
- [44](#) [Type BN2 Uni-Wedge®](#)
- [46](#) [Steelwork Dimensions](#)

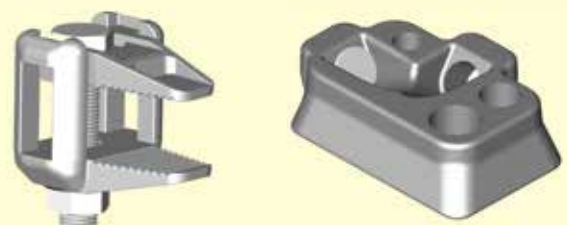



# Markets & Applications

**BEAMCLAMP** and **BOXBOLT** products can be used across all industries where joining steel together is a requirement. The examples below present some of the most common applications and industries we are involved in.



## Infrastructure



**BEAMCLAMP** products are used for a variety of applications within the civil sector for rail, road, water treatment plants and in power generation. These applications are usually for attaching secondary steelwork to existing infrastructure.

Applications on bridges include the installation of strengthening steelwork, walkway systems and the suspension of services to the bridge structure. On Water treatment plants our **BEAMCLAMP** products are used for securing guardrail to protect the filtration tanks in addition to many other applications.

## Steel Construction



Within the structural sector our products are used extensively for the connection of structural steel for both permanent or temporary situations. Our clamps are commonly used for secondary steel or temporary applications when no damage to the existing structure is permitted. They are also used when flexibility of installation is important, hazards from drilling or welding are apparent and access is difficult for power and heavy machinery.

Typical applications include the connection of runway beams for walkways, connecting cladding, securing steel flooring, connecting ballustrading and strengthening of open steel joist frames.

## Solar & Wind Energy



**BEAMCLAMP** and **BOXBOLT** products are used in the solar and wind energy sector extensively. Our clamps are used for securing solar panels to supporting frames and for securing brackets to existing structures that will in turn support the solar panels. Within the wind sector, a variety of our products are utilised on wind turbines. Typical applications are the use of our **FLOORFIX** and **GRATEFIX** for securing steel flooring and grating on the inside of the platforms.

# Markets & Applications

## Building Services



A range of **BEAMCLAMP** products is suitable for use within the building services industry. We have a variety of solutions for the connection of building services equipment to steel structures.

Applications include the connection of mechanical services (pipe work), Heating Ventilation and Air-Conditioning systems, electrical services and fire protection services.

## Facades and Curtain Walling



**BOXBOLT** and **BEAMCLAMP** are used in the facade and curtain walling sectors extensively. **BOXBOLT** provides a solution for the connection of curtain walling brackets to hollow structural sections. **BEAMCLAMP** also offers a clamping solution for securing curtain walling or cladding supports to the existing structure.

## Oil and Gas/Processing Plant



**BEAMCLAMP** products are extensively used offshore. The majority of the applications connect new steel to existing structures. The major benefit being that no drilling or welding is required on-site and in most applications hot work is forbidden, therefore clamping is the ideal solution. All products across the range can be used for applications such as pipe supports, monorail systems, flooring sections, blast walls and helideck expansions.

## Material Handling & Conveyors



**BEAMCLAMP** products are extensively used for material handling applications due to their flexibility and their ability to be removed without damaging existing steel. These can be temporary solutions such as lifting points or more permanent solutions connecting conveyor supports that can then be relocated if required. Common applications are also installations of runway beams for cranes to existing steel and free-standing frames for gantry cranes.

## Stadiums & Amphitheatres



Our products are used within steel structured stadiums and amphitheatres for a variety of applications.

**BEAMCLAMP** products are used for attaching secondary brackets to the existing steel for floodlights, display screens, tannoy systems and general building service equipment. **BOXBOLT** is also used for the connection of guard railing, securing of steel flooring and the connection of seating to the support structure.

## BoxBolt® Used on Splice Connection for Train Platform Structure



Stainless Steel **BOXBOLT** fixings were used to create a splice detail (tube within tube) to create the neat looking steel structure that was then glazed to create a sheltered area for transit passengers. The **BOXBOLT** detail allowed for the neat tubular joint to be made without the need for expensive labour or equipment on site.



## BeamClamp® Types BA and BB used to install a monorail system

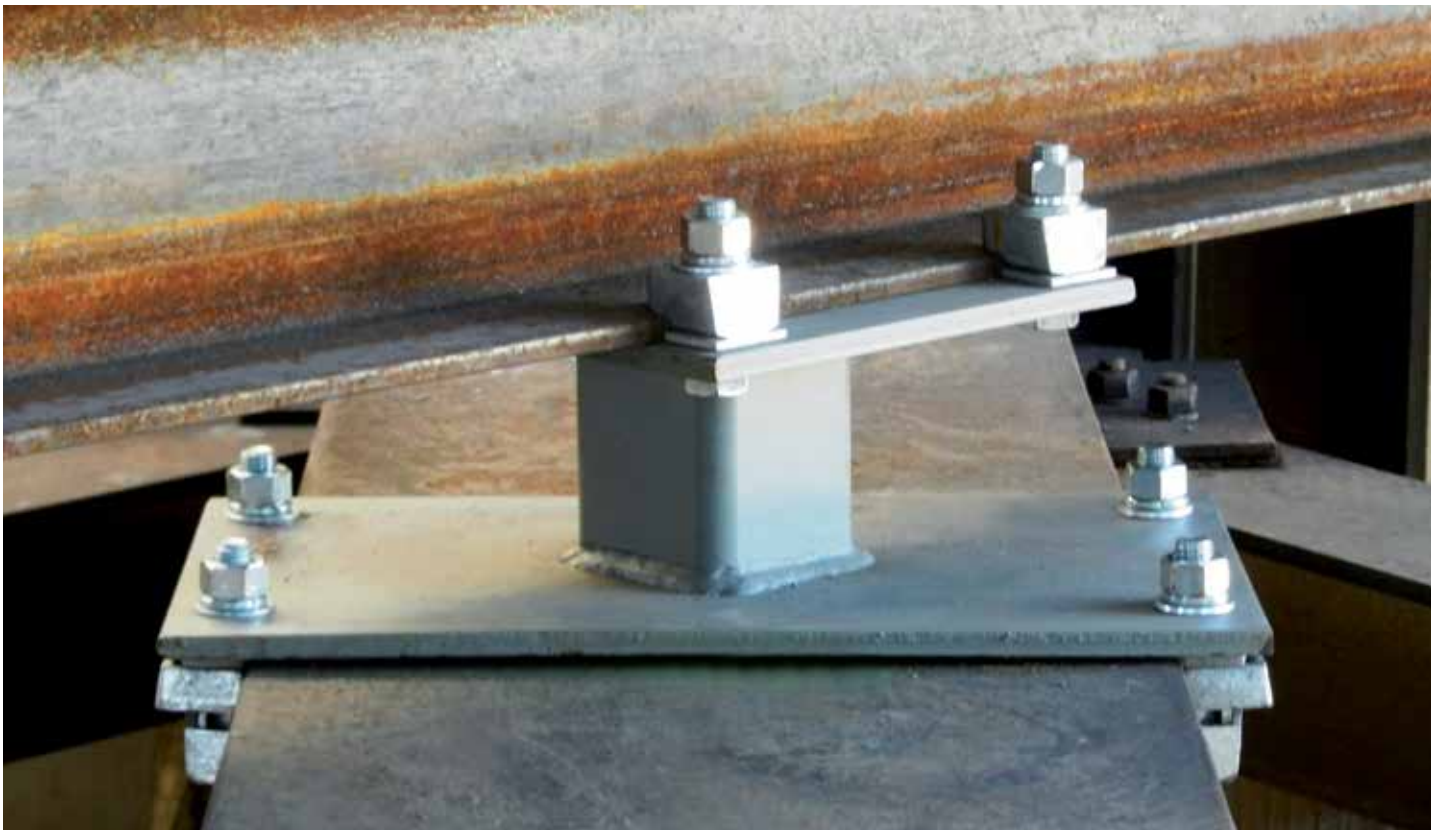

Our Types BA and BB Clamps were used in various configurations to install a monorail system to run the length of the building. The monorail was installed to allow for the old mechanical units to be removed and replaced. The monorail system may be left in situ for future work but by using our flexible system it can be removed if access above is required quickly.

## Suspension of LED display screen using BK Rigging Clamps



Our BK Rigging clamps were used to provide a suspension point to the roof trusses in a shopping mall. The suspension points were used to hang heavy duty wire that suspended a large LED display screen for the shopping mall customers. The use of our BK rigging clamp assembly avoided the need to break the painted surface of the existing steel and also allowed for final adjustment on site.



# What is BoxBolt® ?



A KEE SAFETY PRODUCT

## BoxBolt® Guide - Eurocode 3 / DIN 18800

**BOXBOLT** is a fully tested and approved blind fixing solution for connecting to hollow section steelwork or where access is restricted to one side only. The **BOXBOLT** fixing is suitable for use with rectangular, square and even circular hollow sections. **BOXBOLT** features a hexagon head design to aid installation with a standard spanner but also allows it to be installed with our unique **BOXSOK** installation tool for when installation time needs to be kept to an absolute minimum.

**BOXBOLT** is available in three finishes, these are: Zinc Plated for the less aggressive environments, Hot Dip Galvanised for the more aggressive environments and Stainless Steel for the most arduous of applications. These finishes combined with three lengths of **BOXBOLT** make it extremely flexible to suit its environment and application.

**BOXBOLT** is approved for use by Lloyds Register (LR) type approval and the Deutsches Institut für Bautechnik (DIBt). Our DIBt approval complies with Eurocode 3 / DIN 18800 providing the designer and user with total confidence and peace of mind.

To make the specification of **BOXBOLT** quick and safe we have an easy to use Design Guide that explains how to design a connection using **BOXBOLT** with a calculation sheet to support this that can be referenced for your project.

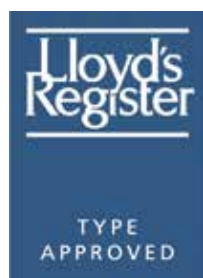

Features	Advantages	Benefits
No Access to both sides of the connection required.	Connection can be made blind for connections into hollow section or where access is restricted.	No through bolting or strapping required reducing fabrication work.
No need for close tolerance holes or tapping.	New holes can be drilled quickly on-site if required.	Flexibility and reduced on-site installation time.
No special tools required - two spanners only.	No hire/purchase of specialist equipment or the need to move around heavy equipment.	Reduction in installation cost and administration.
Installation by semi-skilled labour.	Connections can be made much quicker without special skills or equipment.	Reduction in labour and hire costs.
Only BOXBOLT head visible when installed.	Aesthetic connection.	Flexibility in Architectural design.
Approved for use by Lloyds Register Type and DIBt.	Third party accreditation for use in tensile and shear applications.	Confidence that the connection will perform as stated without site proof testing required.
Exceptional Shear loading performance.	Less BOXBOLT fixings can be used to make shear connections.	Flexibility in design and possible cost reductions.
AISC and Eurocode 3 Method for designing connections.	Provides a simple to follow design procedure that is the same as standard bolted connections.	Designers easily recognise the method and can save costs on competitive methods.
BOXSOK rapid installation tool.	Unique installation tool for speeding up installation.	Reduction in on-site labour costs.

## Diameter and positioning of holes

Dia.	Dim A	Dim B	Dim C	Tolerance
M06	30	11	11	+1,00, -0,25
M08	35	13	14	+1,00, -0,25
M10	40	15	18	+1,00, -0,25
M12	50	18	20	+1,00, -0,25
M16	55	20	26	+2,00, -0,25
M20	70	25	33	+2,00, -0,25

**Note:** Min edge distance = Dim B plus the thickness of hollow section

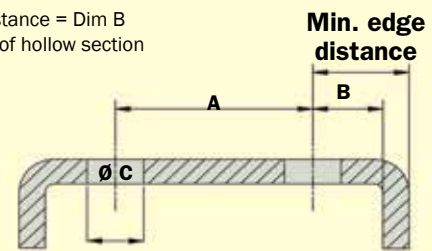

Select the type of finish you require on the **BoxBolt** by replacing the \_ in the code with a **Z** for zinc plated, a **G** for Hot Dip Galvanised or an **S** for Stainless Steel. Example: **BQ2G12** is a **M12 BoxBolt** size **2** in **Hot Dip Galvanised** Finish.

\* BQ1Z06 is tested at an external test house but is not approved by LR type or DIBt.

## BoxBolt<sup>®</sup> Technical Data

Part Number & description			Dimensional information							Technical		Load information			
BoxBolt	Product code	Size	Setscrew length (mm)	Fixing range (dim x)		Across Flats of collar (mm)	Collar thickness (mm)	Dim A (mm)	Dim B (mm)	Hole size (mm)	Torque (Nm)	Galvanised/Zinc Plated Tensile (kN) Shear (kN)		Stainless Steel Tensile (kN) Shear (kN)	
M06	BQ1Z06*	1	45	4	24	17	5	30	11	11 +1,0,-0,25	13	5.71	16.21	/	/
M08	BQ1_08	1	50	5	26	22	6	35	13	14 +1,0,-0,25	25	12.86	21.07	13.29	26.14
	BQ2_08	2	70	18	46	22	6	35	13	14 +1,0,-0,25	25	12.86	21.07	13.29	26.14
	BQ3_08	3	90	30	66	22	6	35	13	14 +1,0,-0,25	25	12.86	21.07	13.29	26.14
M10	BQ1_10	1	50	5	23	24	7	40	15	18 +1,0,-0,25	45	24.07	37	21.07	47.07
	BQ2_10	2	70	18	43	24	7	40	15	18 +1,0,-0,25	45	24.07	37	21.07	47.07
	BQ3_10	3	90	35	63	24	7	40	15	18 +1,0,-0,25	45	24.07	37	21.07	47.07
M12	BQ1_12	1	55	5	25	26	8	50	18	20 +1,0,-0,25	80	29.43	48.29	30.64	59.86
	BQ2_12	2	80	20	50	26	8	50	18	20 +1,0,-0,25	80	29.43	48.29	30.64	59.86
	BQ3_12	3	100	40	70	26	8	50	18	20 +1,0,-0,25	80	29.43	48.29	30.64	59.86
M16	BQ1_16	1	75	5	35	36	9	55	20	26 +2,0,-0,25	190	52.29	88.21	57.07	108.57
	BQ2_16	2	100	30	60	36	9	55	20	26 +2,0,-0,25	190	52.29	88.21	57.07	108.57
	BQ3_16	3	120	55	80	36	9	55	20	26 +2,0,-0,25	190	52.29	88.21	57.07	108.57
M20	BQ1_20	1	100	8	42	46	11	70	25	33 +2,0,-0,25	300	92	145.36	89.07	181.79
	BQ2_20	2	120	35	72	46	11	70	25	33 +2,0,-0,25	300	92	145.36	89.07	181.79
	BQ3_20	3	150	65	102	46	11	70	25	33 +2,0,-0,25	300	92	145.36	89.07	181.79

The above loads are working loads that have the following **Factor of Safety (FOS) Applied: Tensile = 1.925 to 1 Shear = 1.54 to 1**

The loads stated above are based on our DIBt (Deutsches Institut für Bautechnik) approval document Z-14.4-482. The loads shown above are working loads based on the rated loads factored by 1.4 which is an average value between 1.35 used for static loading and 1.5 used for live loads. The rated loads stated in our approval already have a 1.375 factor for tensile and 1.1 factor for shear applied to them. This therefore means that the above loads have a  $1.375 \times 1.4 = 1.925$  to 1 FOS in tensile and  $1.1 \times 1.4 = 1.54$  FOS in shear.

The **BoxBolt** is tested and approved by DIBt (Deutsches Institut für Bautechnik) which complies with the DIN 18800 and Eurocode 3 design methods for bolted steel connections. A design guide and calculator is available when using these methods, please ask our technical team for more information.

The **BoxBolt** is also Lloyds Register type approved for use, should you require a copy of the approval certificate our technical team will be able to assist.

The strength of the material our **BoxBolt** is connecting into should be checked for structural capacity by a structural engineer.

# BoxBolt® Technical Information

The **BOXBOLT** is often used on high profile projects where the aesthetics of the building are essential. It is for this reason the **BOXBOLT** can be adapted to suit the requirements of the Client and the Architect to make the connection pleasing to the eye. The most common versions we can offer are shown here. Should you require a different style then please contact our technical department.

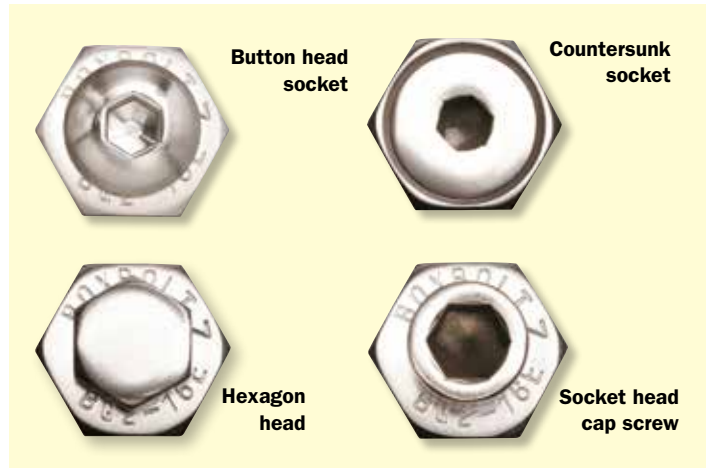

## BOXSOK Rapid Assembly Tool



The **BOXSOK Installation Tool** is a unique rapid assembly tool for the **BOXBOLT** fixing. This specially designed socket holds the hexagon shoulder on the body to stop it rotating whilst allowing the inner socket to tighten up the core bolt. The core bolt draws the cone up inside the slotted body of the sleeve and expands the individual fins inside the connection. The **BOXSOK** eliminates the need for two tools to install the **BOXBOLT**; this considerably speeds up the installation process and also reduces the risk of trapping hands between two tools. The **BOXSOK** device is available to suit all **BOXBOLT** diameters.

## BOXSOK Dimensions

Dia. BOXSOK	Dim A	Dim B	Dim C	Drive D
	(mm)	(mm)	(mm)	(in)
<b>M06</b>	111,5	85,0	30,0	1/4"
<b>M08</b>	112,0	85,5	34,0	3/8"
<b>M10</b>	113,0	86,5	38,0	3/8"
<b>M12</b>	114,0	87,5	42,0	3/8"
<b>M16</b>	114,5	88,0	50,0	1/2"
<b>M20</b>	115,5	89,0	59,0	1/2"

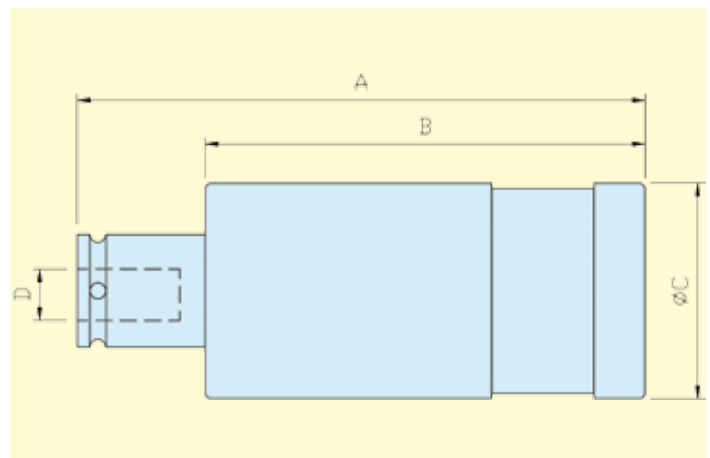



# BoxBolt® Installation Instructions

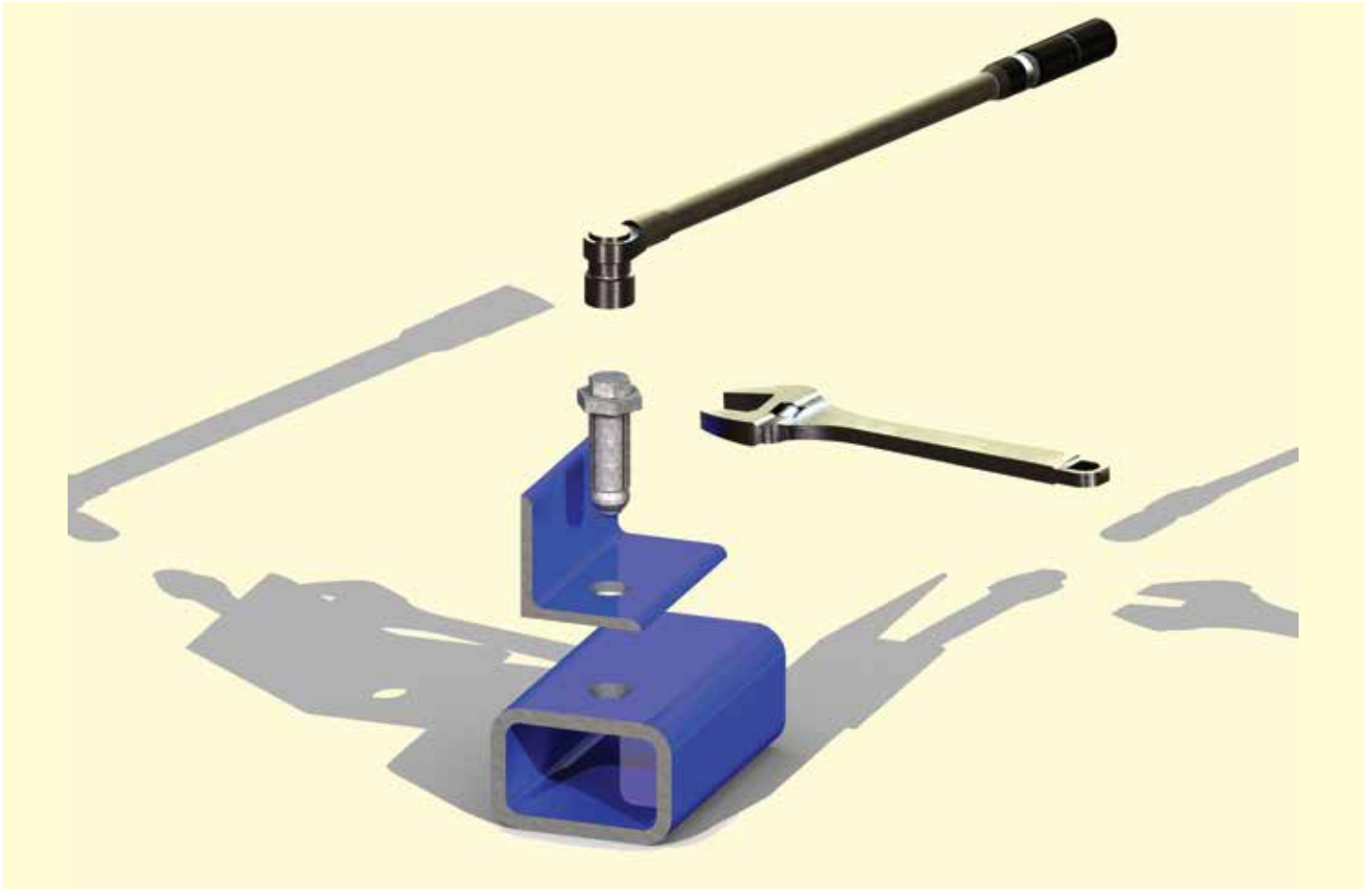

**STEP 1:** Align the holes in the bracket to be secured with the pre-drilled hole in the structural tube. Insert the **BOXBOLT** through both pieces of steel until the underside of the shoulder is flush with the outside of the steel.

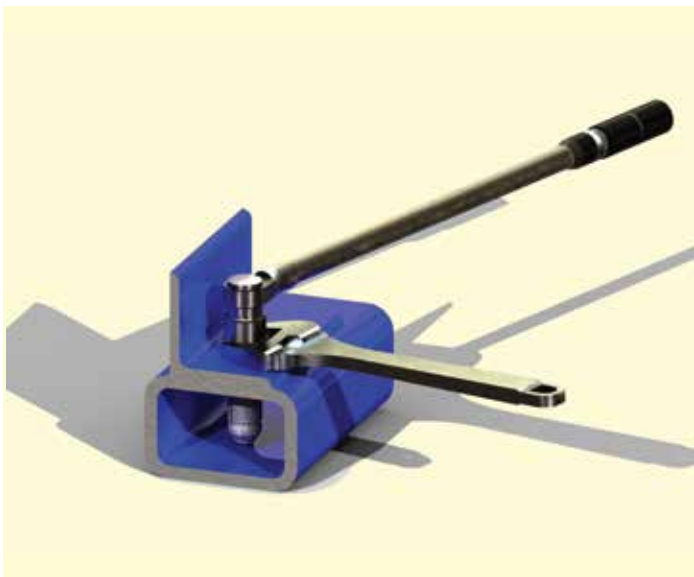

**STEP 2:** Hold the hexagon shoulder of the **BoxBolt** with an open ended wrench. Use an impact wrench or ratchet to tighten the core bolt.

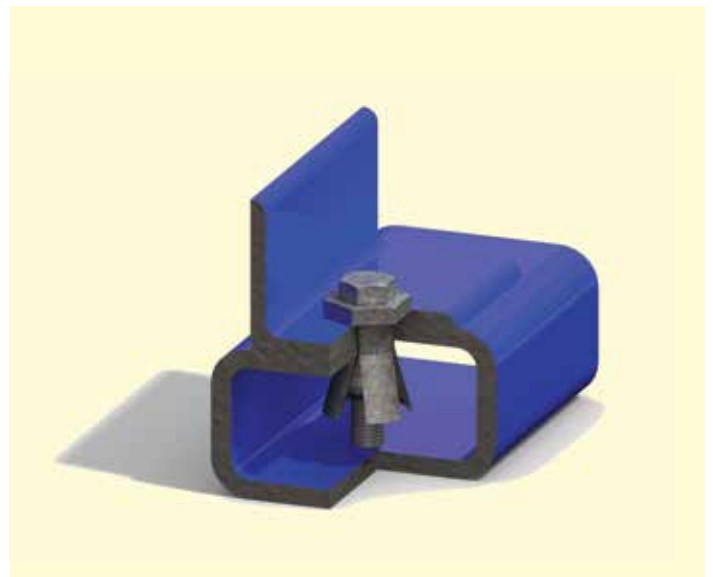

**STEP 3:** Remove the open ended wrench and check to ensure that the core bolt is tightened to the recommended torque.

# BoxBolt® Application Examples

1



Two hollow sections at 90 degrees using an end plate

2



Hollow section below an I-Beam at 90 degrees using a combination of BOXBOLT and BEAMCLAMP fixings

3



Two hollow sections at 90 degrees using angle brackets

4

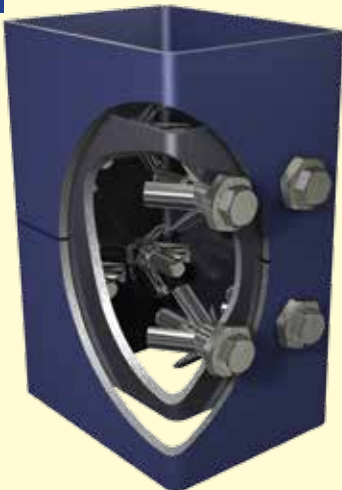

Hollow section sleeve connection creating an aesthetic joint from the outside

5

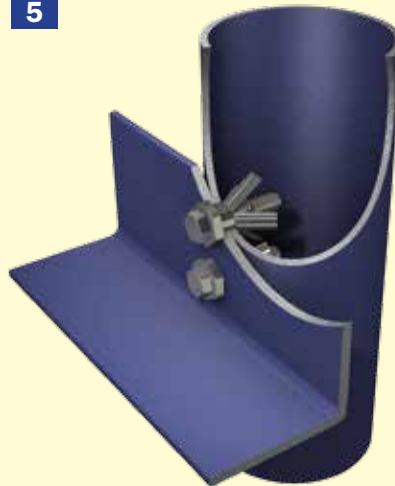

Angle to vertical hollow section post

6

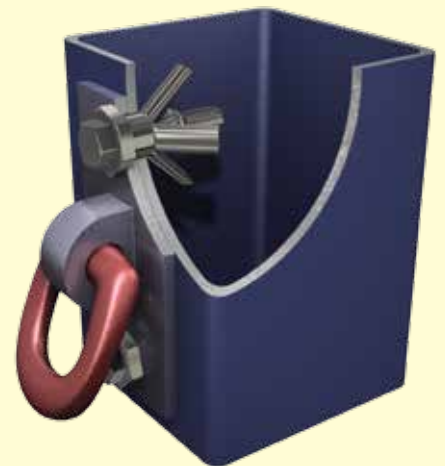

Rigging point to outside of hollow section

7

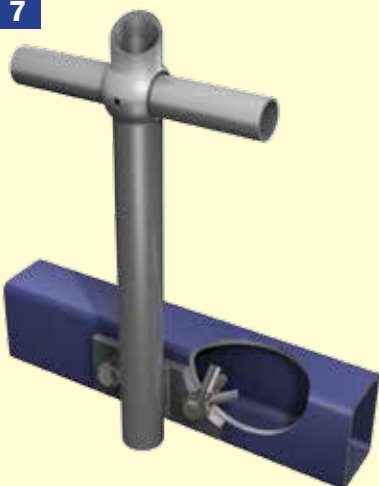

Side fixing of handrail base to hollow section

8



Top fixing of handrail base to hollow section

9

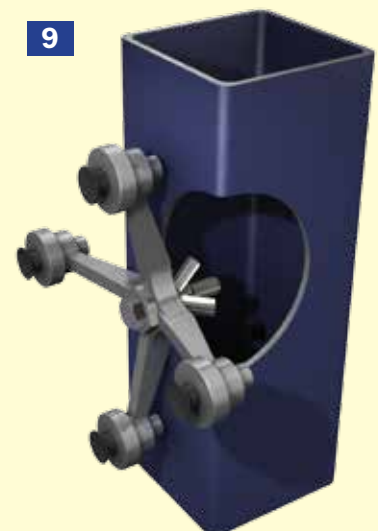

Glazing bracket to hollow section



**BEAMCLAMP** is an extensive range of clamping products designed for making steel to steel connections without the need for drilling or welding. The clamping system gives the specifier the peace of mind that once the connection is made it has a guaranteed safe working

load and it also provides flexibility for the user when installing and reduces the overall cost. The system is also ideal for areas where drilling or welding is not allowed or access and power is restricted.

## Features

- **Third party approvals (Lloyds & DIBt)**
- **Guaranteed 5 to 1 Factor of Safety**
- **No special tools or skilled labour required**
- **Hot Dip Galvanised as standard**
- **Easy to adjust on site**
- **No weakening of existing steelwork**
- **No damage to protective coating on the steelwork**

## Technical Support

We offer a full engineering service to support our products which includes recommendation of an individual product through to a full design capability for a large project. Our technical team has **2D/3D Computer Aided Design (CAD)** capabilities combined with **Finite Element Analysis (FEA)** for the design of the more complex products or applications. Our Technical Sales Engineers perform regular **Continuous Professional Development (CPD)** seminars to educate the design engineers on how to specify our clamping products.

## Benefits

- **Peace of mind when specifying or installing**
- **Provides safe connections**
- **Savings in installation time and cost on-site**
- **Excellent long term corrosion resistance for external applications**
- **Provides flexibility to allow for site tolerances**
- **Structural integrity of steelwork remains unchanged**
- **Integrity of existing steelwork coating remains unchanged**

## Approval

All the loads stated in our catalogue have been derived from physical testing and where you see an approval symbol they have also been approved by that particular body. The majority of the range is **Lloyds Register Type Approved** and the **Types BA, BB, BF1, BG1, BH1** have the additional approval of the **Deutsches Institut für Bautechnik (DIBt)**





# BeamClamp® Connection Designer in 3 easy steps



The **Connection Designer** is a powerful tool available on our website to help design a connection and produce an engineering drawing for you without the need for any CAD capabilities.

The **BEAMCLAMP** connection designer allows you to design a unique connection in three easy steps. Providing the information entered is within the capacity of our fixings it will produce a full, detailed specification with a drawing of the connection that can be saved, printed, e-mailed or faxed. It is just as easy as 1 2 3.

## STEP 1

Select the type of steel that you are connecting to the section that is intended to be at the top.

## STEP 2

Select the type of connection you wish to make from the variety of common details.

## STEP 3

Enter the load details and specification of your steelwork and press calculate.

**Connection Designer**  
[www.beamclamp.com/resources/beamclamp-configurator](http://www.beamclamp.com/resources/beamclamp-configurator)

Item	Qty	Desc.
1	4	Grade 8.8 bolt complete with nut and flat washers (12mm x 80mm)
2	4	Upper Component(s) (including any packing) BB1G12 + BH1Z12 + BG1G12
3	1	Location Plate 357mm x 257mm x 8mm thick
4	4	Lower Component(s) (including any packing) BA8G12

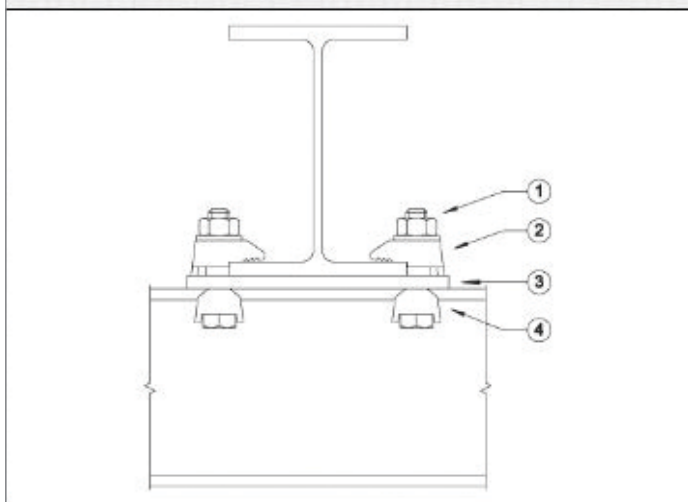

Reference Data	Kee Safety Ltd Cradley Business Park, Overend Road West Midlands, RG2 0NH Tel: +44 (0) 1884 652 188 Fax: +44 (0)1884 652 192 <a href="http://www.beamclamp.co.uk">http://www.beamclamp.co.uk</a>	
Upper Beam: HE 800 B Lower Beam: HE 200 A Load per Connection: 22kN Safe Working Tension Load per Connection: 23.01kN All loads guaranteed with 5:1 Factor of Safety	Assembly Part Number: W12977 Project Reference: BeamClamp Solution Customer: Dave Smith	

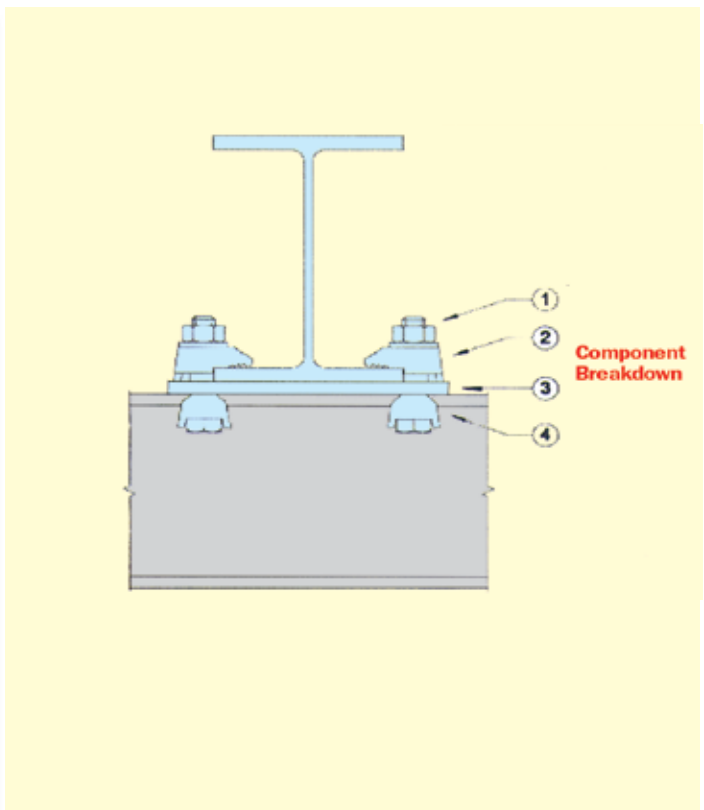

When designing a connection using our clamps it is very useful to have a block of them that can be incorporated in to your drawings. Our CAD blocks are available on the website [www.beamclamp.com](http://www.beamclamp.com).

# BeamClamp® Components Type BA & BB

The types **BA** and **BB** are commonly used in pairs to clamp two steel sections together. The type **BA** has a recessed top to grip the head of a grade 8.8 setscrew or bolt, this allows a nut and washer to be tightened down on to the flat top of the **BB** using one tool only. Both clamps are available with three tail lengths **1,2 or 3 (dim E)**, this should be as near to the thickness of steel it is clamping on or slightly less if an exact match is not possible. Packing pieces **BF1, BG1** and **BH1** can be used in combination with the tail length to achieve a match to the steel flange, please see page 24 for these items. **BA** and **BB** types are suitable for parallel flanges and flanges up to 8 degrees taper. They can also be used on their own if one piece of the steelwork has been pre-drilled. To simplify the selection of tail lengths and packing pieces please see the tables on pages 30 to 31. Please note when using tapered steelwork it is the edge of the steel that we require, see our tables on pages 50 and 51 for edge thickness dimensions.

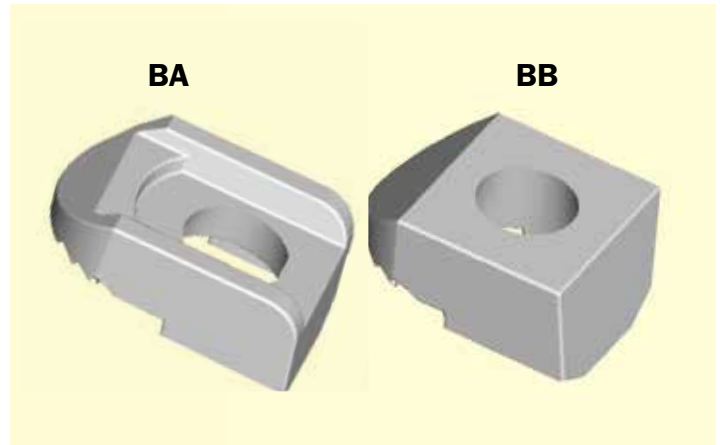

- Hot Dip Galvanised to BS EN ISO 1461
- Manufactured from Ductile Iron to BS EN 1563
- 5 to 1 Factor of Safety
- Lloyds Register approved
- DIBt approved



The Safe Working Loads are based on assemblies tested in typical conditions

Product code	Product code	A Bolt dia. (Grade 8.8)	B (mm)	C (mm)	D1 (mm)	D2 (mm)	E (mm)			Width (mm)	Torque (Nm)	Tensile SWL (kN) per bolt (5:1 Factor of Safety)	Frictional SWL (kN) per four bolts (5:1 Factor of Safety)
							1	2	3				
BA G08	BB G08	M08	9	16	5	9	/	4	/	20	6	1.25	/
BA G10	BB G10	M10	12	20	6	11	4	5	7	26	20	2.5	/
BA G12	BB G12	M12	15	25.5	7	13	4.5	6	9.5	29.5	70	5.75	1.3
BA G16	BB G16	M16	17	31	9	17	5.5	8	11	36	150	9.87	3.9
BA G20	BB G20	M20	21	35	11	21	7	10	12.5	44	290	16.47	11
BA G24	BB G24	M24	26	49	13	25	9	12	16	53	490	21.1	18

Do not exceed the Safe Working Load (SWL) specified

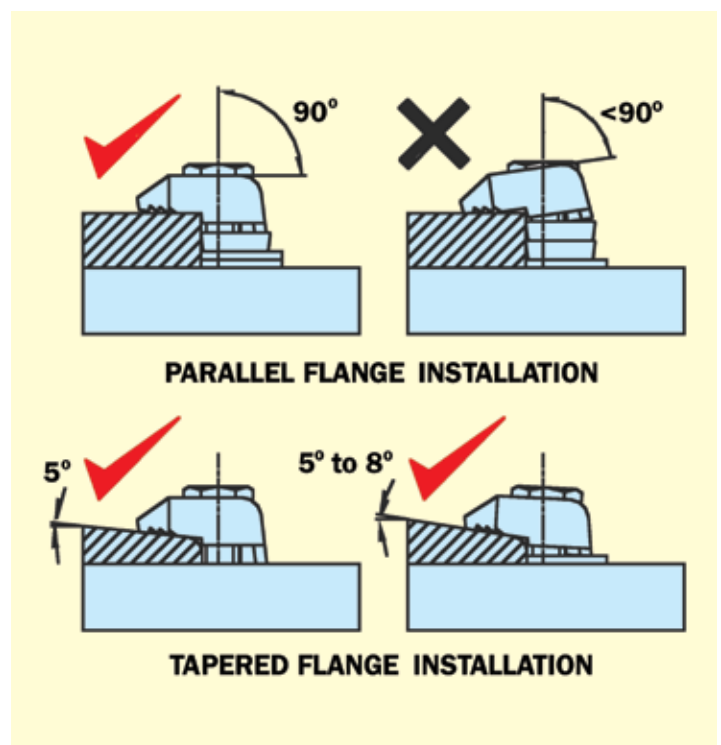
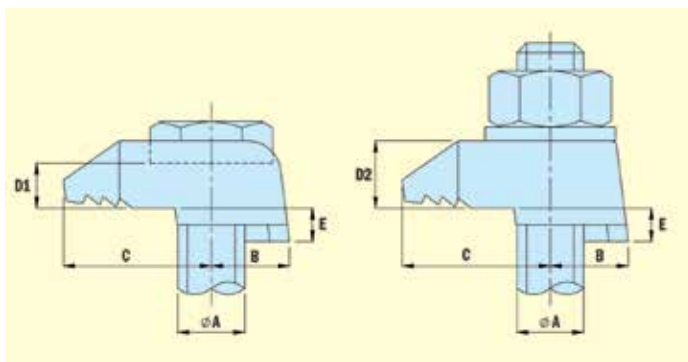

# BeamClamp® Components Type BK1

The **BK1** is a self adjusting fixing that consists of two parts. The main body provides a recess to allow a hemispherical washer to be seated. This allows the body to adjust between a specified clamping range and as the washer rotates it provides a flat surface for a nut. This mechanism makes the product suitable for clamping to tapered steelwork of up to 15 degrees, it is also extremely useful for projects where the thickness of steel may vary. The **M08, M10 and M12** versions feature a tab at the back edge that can be located in the open ends of strut products, both aiding installation and preventing rotation once installed. Should the maximum clamping range be exceeded our BF2 and BG2 packers can be used to increase it, please see page 24 for details.



- **Hot Dip Galvanised BS EN ISO 1461**
- **Manufactured from Ductile Iron to BS EN 1563**
- **5 to 1 Factor of Safety**
- **Lloyds Register approved**
- **Self adjusting body style**



The **Safe Working Loads** are based on assemblies tested in typical conditions.

Product code	A Bolt dia. (Grade 8.8)	B1	B2	C	D	Width	Torque (Nm)	Tensile SWL (kN) per bolt (5:1 Factor of Safety)	Frictional SWL (kN) per four bolts (5:1 Factor of Safety)
BK1G08	M08	3 to 12	3 to 9	37	14	41	6	1.25	0.21
BK1G10	M10	3 to 15	3 to 12	47	21	41	20	3.13	0.43
BK1G12	M12	3 to 18	3 to 15	48	17	41	70	10.04	1.41
BK1G16	M16	3 to 24	N/A	61	22.5	47	150	16.10	3.39
BK1G20	M20	3 to 30	N/A	73	26	58	290	26.44	5.63

Do not exceed the **Safe Working Load (SWL)** specified

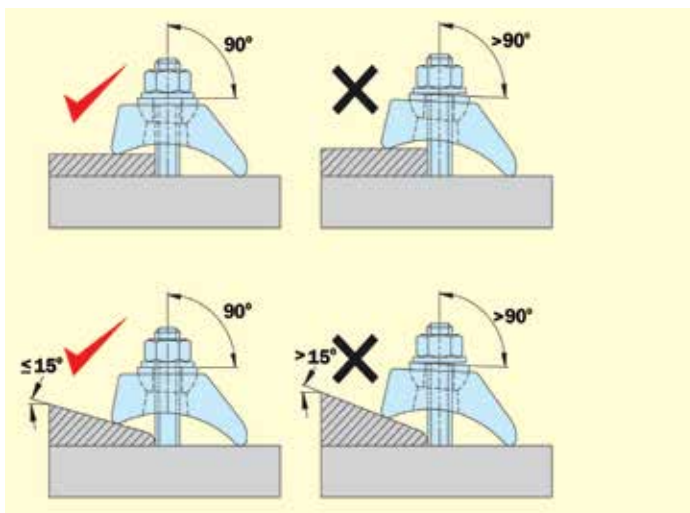
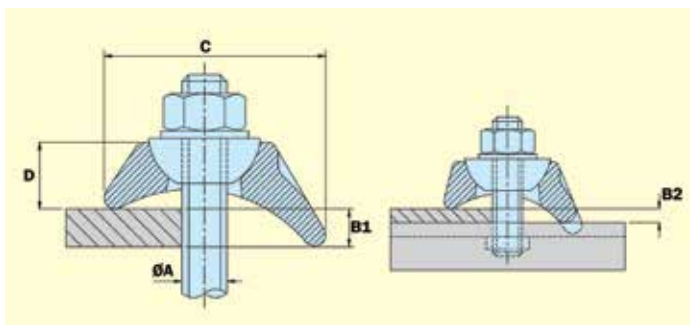



# BeamClamp® Components Type BT & BW

The types **BT** and **BW** are specifically designed with a **10 degrees** sloping nose. This sloping nose makes them ideal for fixing on to tapered steelwork such as RSJ's or crane rail sections. The type **BT** has a recessed top to captivate the head of a grade 8.8 setscrew or bolt, the type **BW** has a flat top to allow a nut and washer to be tightened down on it. Both clamps are available with two tail lengths 1 or 2 (dim E), this should be as near to the thickness of steel it is clamping to or slightly less if an exact match is not possible. Packing pieces **BF1**, **BG1** and **BH1** can be used in combination with the tail length to achieve a match to the steel flange, please see page 24 for these items. The types **BT** and **BW** can also be used on their own if one piece of the steelwork has been pre-drilled. To simplify the selection of tail lengths and packing pieces please see tables on pages 30 and 31. Please note when using tapered steelwork it is the edge of the steel that we require, see our tables on pages 50 and 51 for edge thickness dimensions.

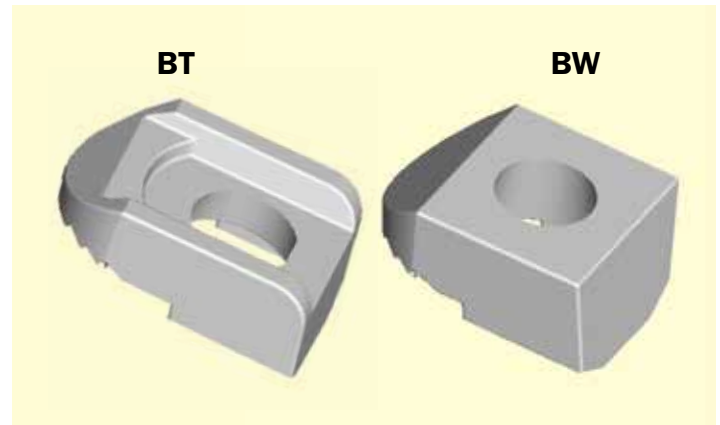

- **Hot Dip Galvanised to BS EN ISO 1461**
- **Manufactured from Ductile Iron to BS EN 1563**
- **5 to 1 Factor of Safety**
- **10 degrees nose**

The Safe Working Loads are based on assemblies tested in typical conditions

Product code	Product code	A Bolt dia. (Grade 8.8)	B (mm)	C (mm)	D1 (mm)	D2 (mm)	E (mm)		Width (mm)	Torque (Nm)	Tensile SWL (kN) per bolt (5:1 Factor of Safety)	Frictional SWL (kN) per four bolts (5:1 Factor of Safety)
							1	2				
BT G12	BW G12	M12	15	25.5	7	13	4	6	28.5	70	5.75	1.3
BT G16	BW G16	M16	17	31	9	17	6	8	36	150	9.87	3.9
BT G20	BW G20	M20	21	35	11	21	7	10	44	290	16.47	1.1

Do not exceed the Safe Working Load (SWL) specified

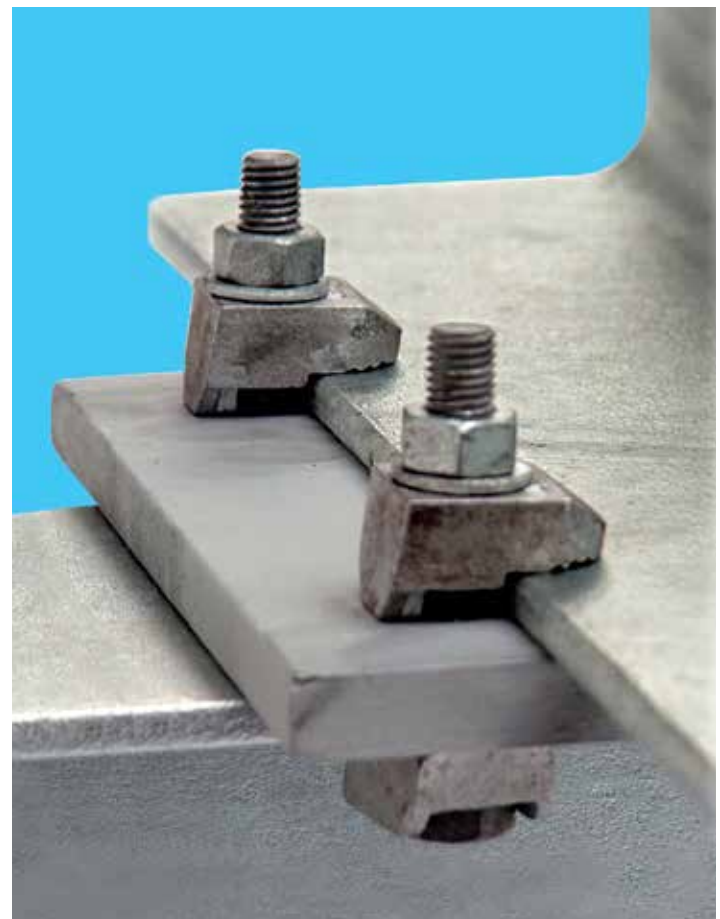
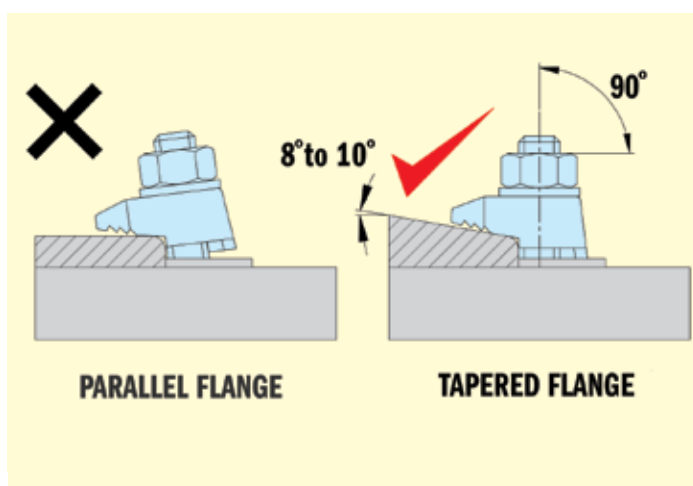
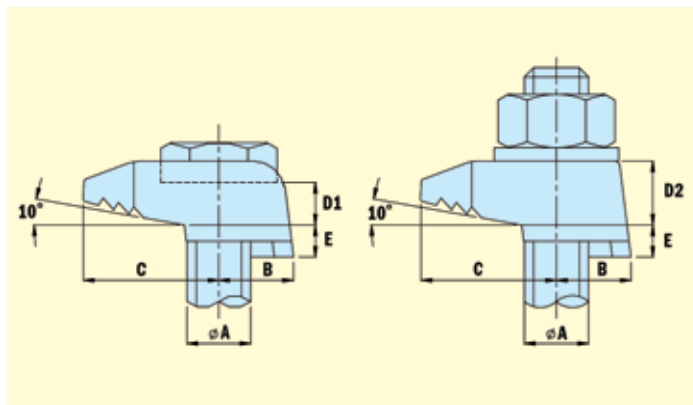

# BeamClamp® Components Type BE1 & BE2

The **BE1** and **BE2** feature a socket screw at the back to provide adjustment for varying steel thicknesses. They are the ideal choice when flange thicknesses are unknown or change on a project as they eliminate the need for packing pieces up to their maximum adjustment (Dim E). Once this maximum is exceeded our **BF2** and **BG2** packers can be used to increase the clamping range, please see page 24 for details. To make the selection of tail lengths and packing pieces easy please see tables on pages 30 and 31. Please note the **BE1** and **BE2** are not suitable for steel flanges with tapers greater than 5 degrees.

- **Hot Dip Galvanised BS EN ISO 1461**
- **Manufactured from Ductile Iron to BS EN 1563**
- **5 to 1 Factor of Safety**
- **Lloyds Register approved**
- **Socket screw adjustment**

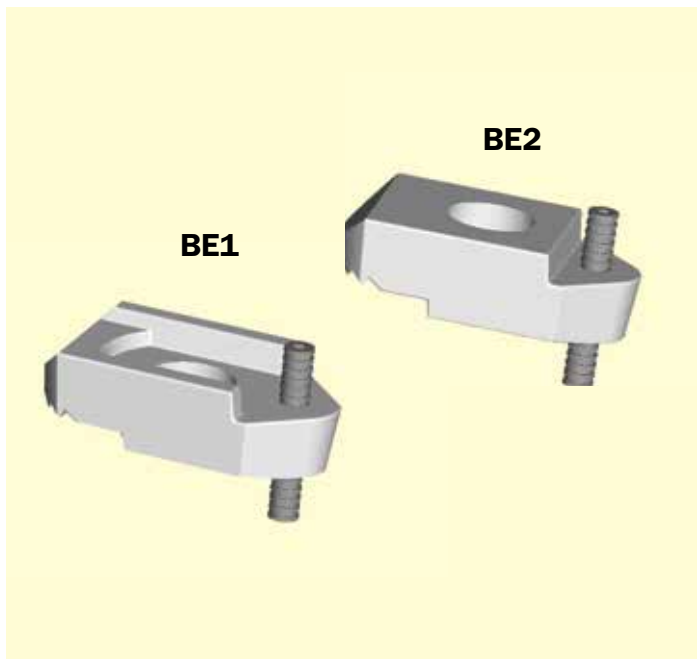

The Safe Working Loads are based on assemblies tested in typical conditions

Product code	Product code	A Bolt dia. (Grade 8.8)	B (mm)	C (mm)	D1 (mm)	D2 (mm)	E (mm)	F (dia)	Width (mm)	Torque (Nm)	Tensile SWL (kN) per bolt (5:1 Factor of Safety)	Frictional SWL (kN) per four bolts (5:1 Factor of Safety)
BE1G10	/	M10	20	20	6	/	5 to 20	M06	26	20	2.5	/
BE1G12	BE2G12	M12	26	25.5	7	13	6 to 22	M06	28.5	70	3.72	1.3
BE1G16	BE2G16	M16	30	31	9	17	7 to 23	M08	36	150	8.25	3.9
BE1G20	/	M20	35	34	11	/	8 to 24	M10	44	290	16.12	11
BE1G24	/	M24	49	49	13	/	10 to 30	M12	53	490	21.1	18

Do not exceed the Safe Working Load (SWL) specified

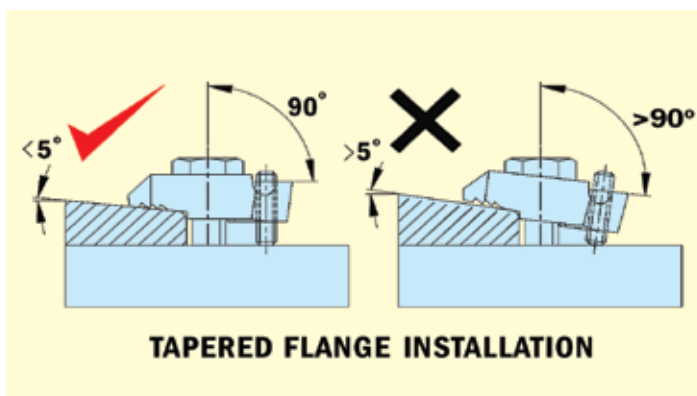
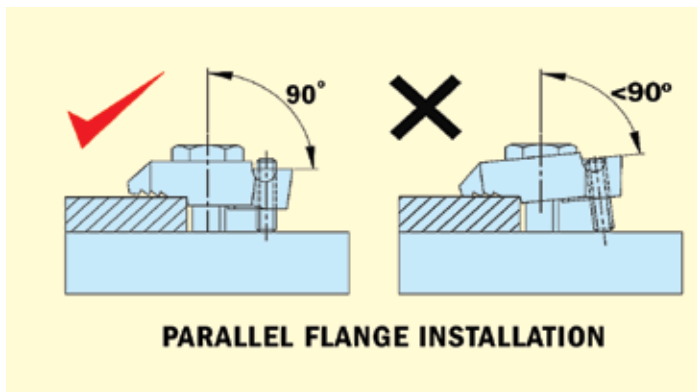
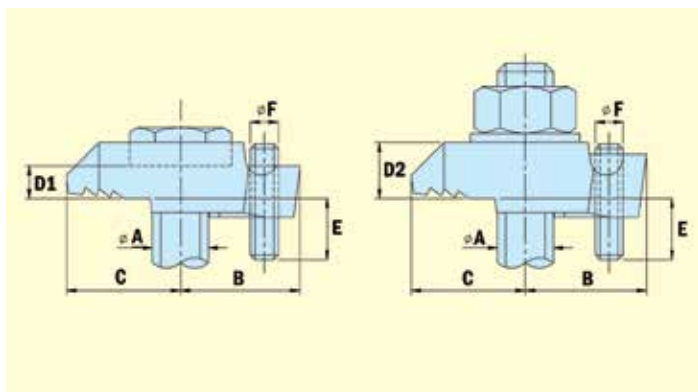

# BeamClamp® Components Type BC1 & BD1

The types **BC1** and **BD1** are designed to hook over the upstanding flanges of angles or channels. They can be used together for channel to channel connections or in conjunction with our other clamping products for making angle/channel connections to other types of steel. The **BC1** features a recessed top to grip a bolt head and the **BD1** has a flat top to allow a nut and washer to be tightened on to it. It is suitable for use with studding or other threaded items but we always recommend the use of grade 8.8 high tensile threaded items.

- Hot Dip Galvanised to BS EN ISO 1461
- Manufactured from Ductile Iron to BS EN 1563
- 5 to 1 Factor of Safety
- Lloyds Register approved

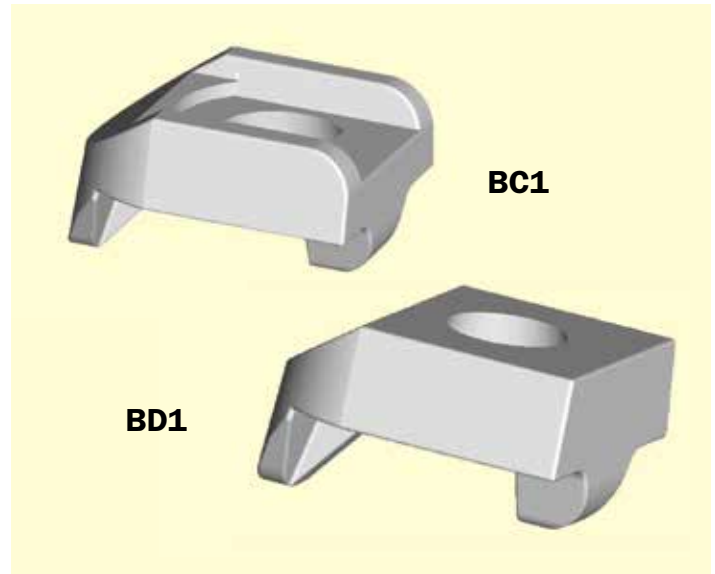

**NB These products are not recommended for frictional loads**

The Safe Working Loads are based on assemblies tested in typical conditions

Product code BC1	Product code BD1	A Bolt dia. (Grade 8.8)	B (mm)	C (mm)	D (mm)	E1 (mm)	E2 (mm)	Width (mm)	Torque (Nm)	Tensile SWL (kN) per bolt (5:1 Factor of Safety)
BC1G08	BD1G08	M08	9	5	6	5	9	22	3	1.25
BC1G10	BD1G10	M10	12	4	7.5	6	11	29	10	2.5
BC1G12	BD1G12	M12	15	6.5	9.5	7	12	31.5	35	4.32
BC1G16	BD1G16	M16	17	8	11.5	9	17	41	75	7.5
BC1G20	BD1G20	M20	21	9	13.5	11	21	49.5	145	11
BC1G24	BD1G24	M24	26	13	17	13	25	60	245	17.17

Do not exceed the Safe Working Load (SWL) specified

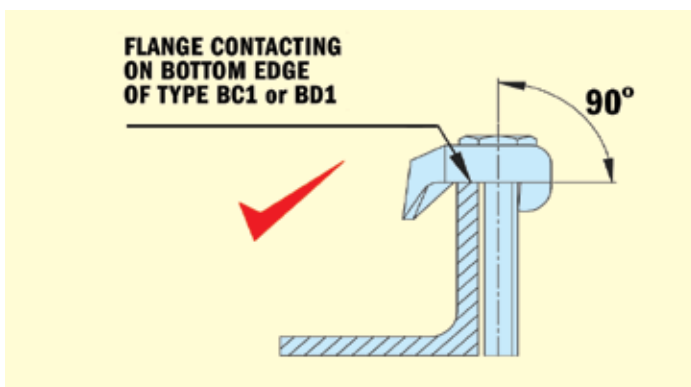
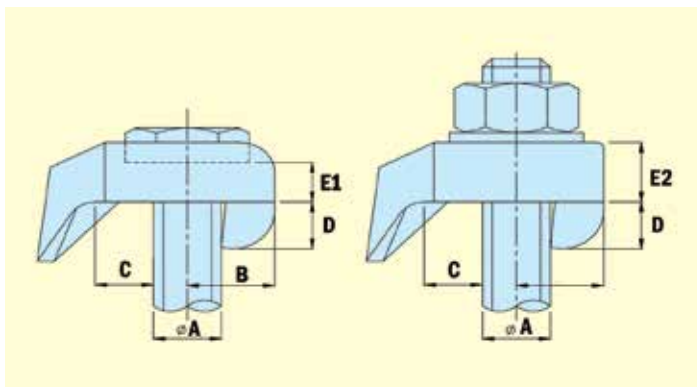



# BeamClamp® BL Flange Clamp

The **BL** Flange Clamp is a heavy duty clamping assembly that is used for securing steel together without the need for a location plate. The two piece design allows it to adjust to different combinations of steel thickness but still ensuring it clamps at 90 degrees to the steel.

Typical applications would be clamping two steel sections of the same width running parallel or for clamping down pressure vessel lids. The recessed part of the clamp captivates the hexagon head of the bolt or nut to prevent rotation and means that installation can be achieved by the use of one tool only.

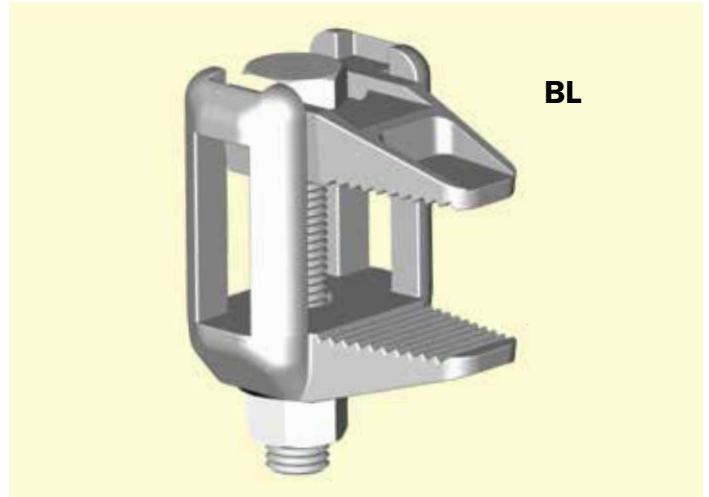

- Only requires one tool for installation
- Hot Dip Galvanised to BS EN ISO 1461
- Extensive fixing range

- Can accommodate clips/brackets
- Tested for Tensile and Lateral Loading

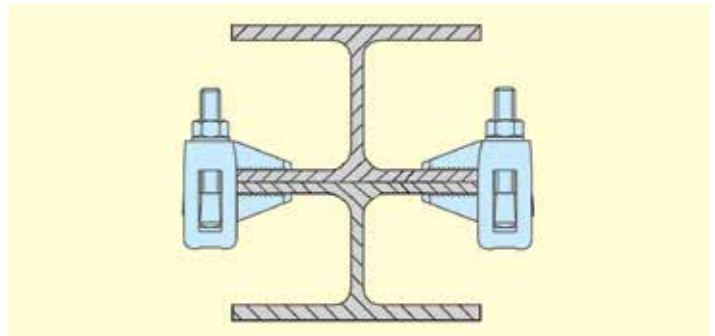
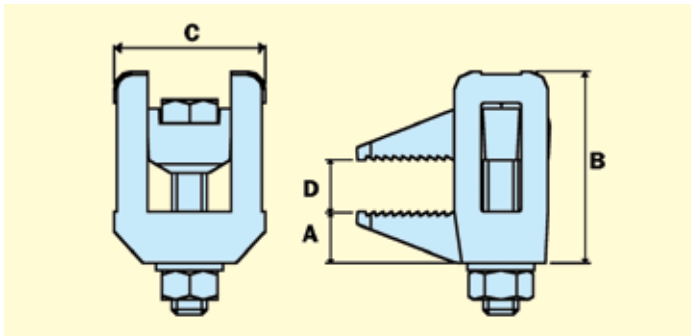

The Safe Working Loads are based on assemblies tested in typical conditions

Product Code	A (mm)	B (mm)	C (mm)	D (mm)	Tightening torque (Nm)	3 to 1 Factor of safety applied		
						Tensile load in line with rod (kN)	Tensile load at nose (kN) (per pair)	Lateral load (kN)
BLG08A	12.5	45	40	5 to 20	10	1.0	7.4	0.25
BLG10A	14	58	47	6 to 30	20	2.5	9.3	0.40
BLG12A	15	65	51.5	7 to 35	40	5.0	11.0	0.60
BLG16A	20	95	58	8 to 55	90	7.5	20.3	0.70
BLG20A	23	116	66	8.5 to 70	180	9.0	23.3	0.75
BLG24A	26	147	75	9 to 95	200	10.5	34.3	0.80

Do not exceed the Safe Working Load (SWL) specified

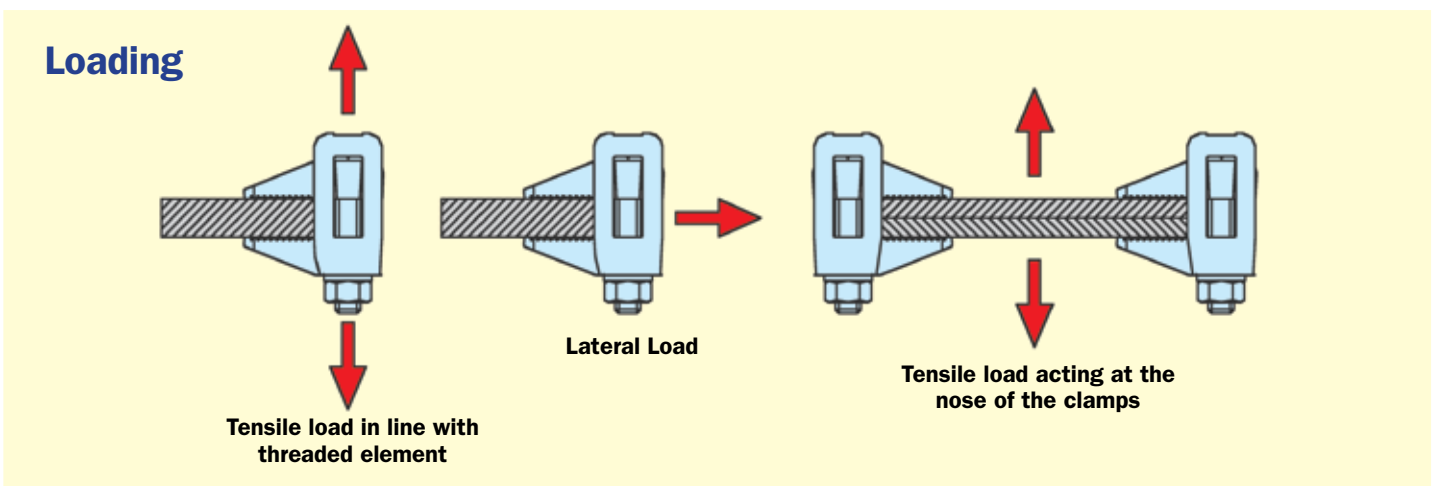

# BeamClamp® Packing Pieces

## Short packers for Types BA, BB, BT and BW

Product code	Bolt dia.	A (mm)	B (mm)	C (mm)	D dia.
BF1G08	M08	4	14	22	10
BF1G10	M10	5	18	28	12
BF1G12	M12	6	22	30	14
BF1G16	M16	8	29	35	18
BF1G20	M20	10	33	43	21
BF1G24	M24	12	45	55	26

### BF1

Product code	Bolt dia.	A (mm)	B (mm)	C (mm)	D dia.
BG1G08	M08	8	14	22	10
BG1G10	M10	10	18	28	12
BG1G12	M12	12	28	30	14
BG1G16	M16	16	36	35	18
BG1G20	M20	20	43	43	21
BG1G24	M24	24	45	55	26

### BG1

Product code	Bolt dia.	A (mm)	B (mm)	C (mm)	D dia.
BH1Z08	M08	2	15	22	10
BH1Z10	M10	2	20	28	12
BH1Z12	M12	2.5	24	31	14
BH1Z16	M16	3	29	38	18
BH1Z20	M20	4	43	44	21
BH1Z24	M24	4	45	55	26

### BH1

## Long packers for Types BE1, BE2 and BK1

Product code	Bolt dia.	A (mm)	B (mm)	C (mm)	D dia.
BF2G08	M08	4	24	22	10
BF2G10	M10	5	30	28	12
BF2G12	M12	6	39	30	14
BF2G16	M16	8	49	35	18
BF2G20	M20	10	58	43	21
BF2G24	M24	12	77	55	26

### BF2

Product code	Bolt dia.	A (mm)	B (mm)	C (mm)	D dia.
BG2G08	M08	8	24	22	10
BG2G10	M10	10	30	28	12
BG2G12	M12	12	39	30	14
BG2G16	M16	16	49	35	18
BG2G20	M20	20	58	43	21
BG2G24	M24	24	77	55	26

### BG2

Our range of packing pieces is designed to provide support to the underside of clamps to ensure they clamp on to the steel at the correct angle. We have a series of short packers designed for the **BA, BB, BT and BW** clamps and a long series for the **BE1, BE2 and BK1** clamps that reach further back on to the supporting steel. The packers can be used in combination with the fixing range of the clamp to ensure a correct fixing. See tables on pages 30 & 31 for the correct combinations for different steel thicknesses.

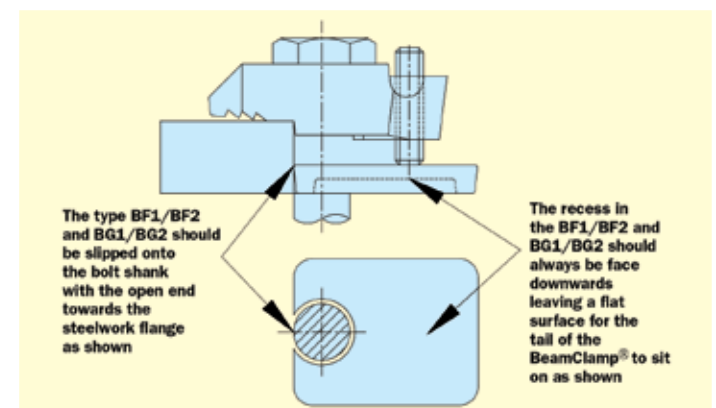
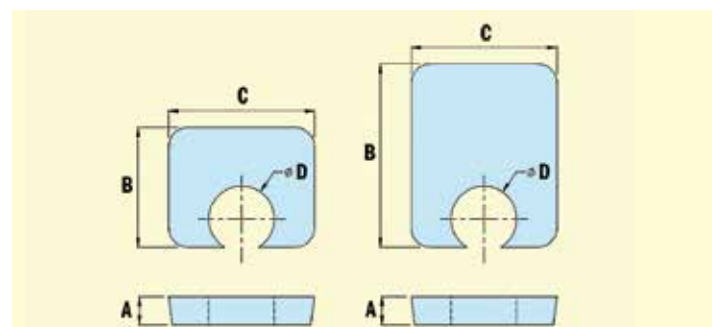
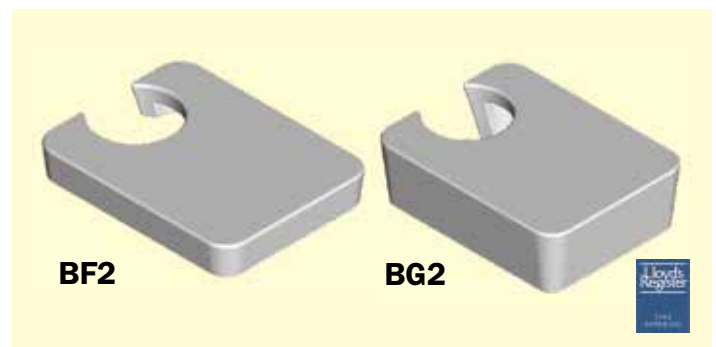
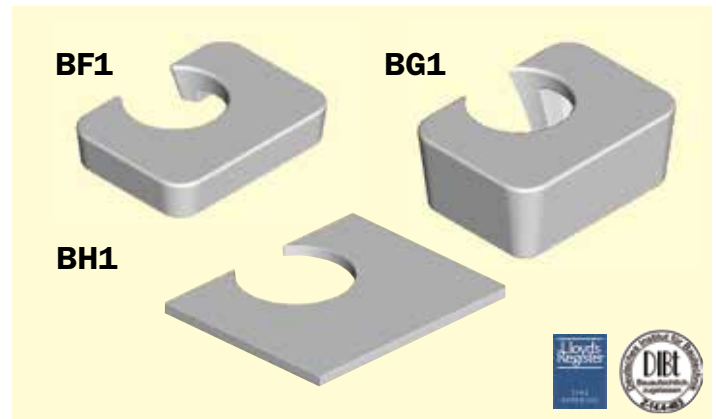

# BeamClamp® Location Plate & Spacers

The location plate is an important part of a **BEAMCLAMP** assembly. It provides support for the rear of the **BEAMCLAMP** fixings to react against while the front of the product clamps down on to the steel.

The hole centres are designed to suit the widths of both the upper and lower members and to ensure that the fixings are located as close to the edge of the steel as possible.

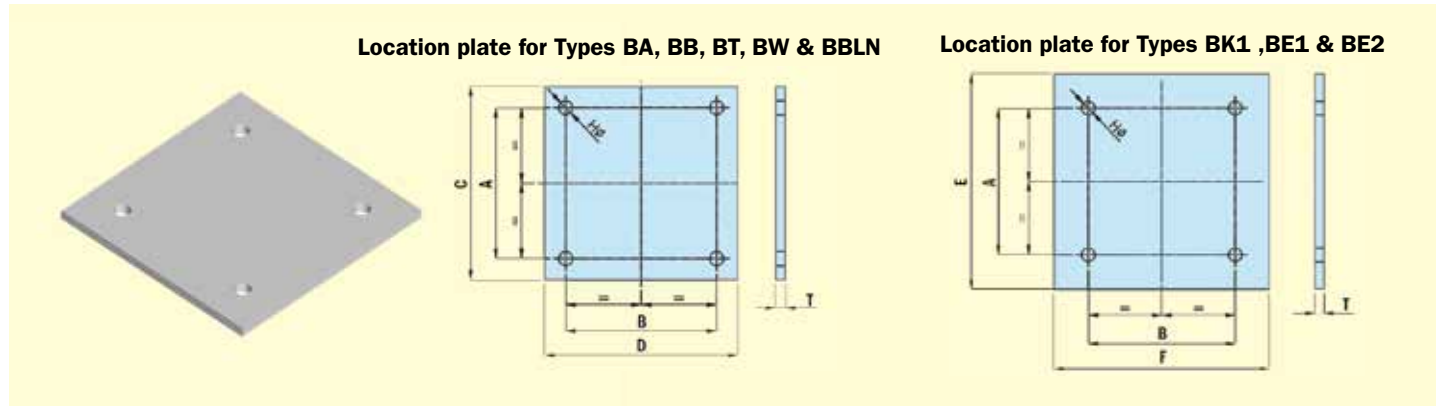

Dimension Table for BEAMCLAMP Location Plates

Bolt Dia.	A (mm) Upper Beam Width +	B (mm) Lower Beam Width +	C (mm) Upper Beam Min width +	D (mm) Lower Beam Min width +	E (mm) Upper Beam Min width +	F (mm) Lower Beam Min width +	H (mm) Dia	T (mm) Min
M08	10	10	40	40	60	60	10	8
M10	12	12	48	48	72	72	12	8
M12	14	14	56	56	84	84	14	8
M16	18	18	72	72	108	108	18	10
M20	22	22	88	88	132	132	22	12
M24	26	26	104	104	156	156	26	15

Thickness of clamps (Dim X)

Bolt Dia	Type BA & BE1	Type BB, BE2 & BBLN	Type BK1
M08	4	8	18
M10	5	10	22
M12	6	12	25
M16	8	16	28
M20	10	20	35
M24	12	24	46

Thickness of nut/washer (Dim N)

Bolt Dia	N
M08	8
M10	10
M12	12
M16	16
M20	20
M24	24

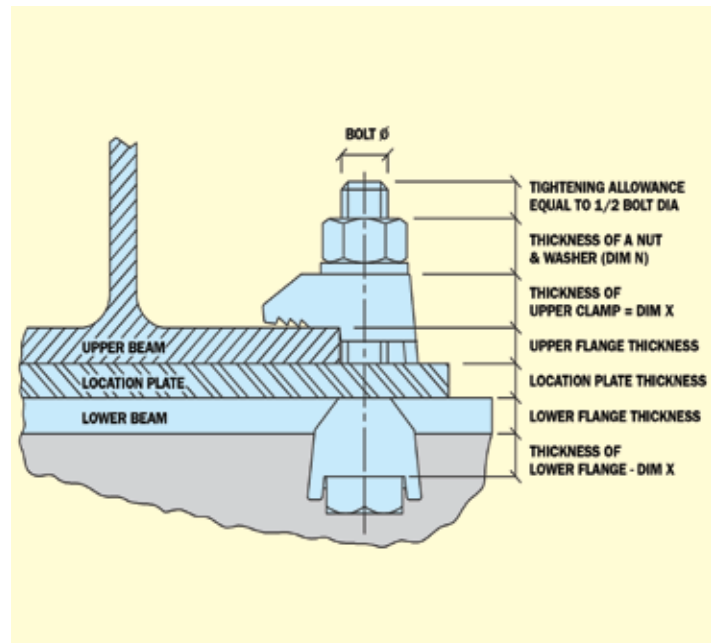
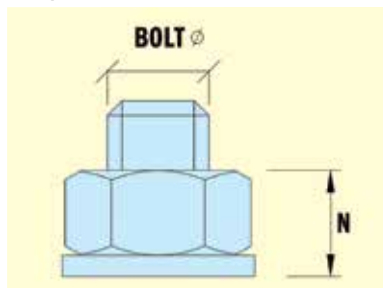

Location plates can be fabricated to suit a variety of applications with different angles of cross over and gaps between sections. We will be happy to assist free of charge with detailing these brackets for your individual applications.

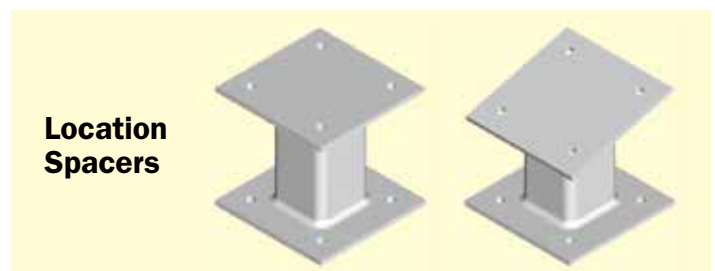

Location Spacers



# Rigging Clamps

The **Adjustable Rigging Clamp** is a self adjusting, ready to install clamp capable of safe working loads of up to 22.2 kN. The shackle connection allows loads to be applied up to 45°. The Adjustable Rigging Clamp can accommodate a variety of flange widths and thicknesses and is installed without the need for any drilling or welding to the support beam.

The Adjustable Rigging Clamp is available in five standard sizes to accommodate any flange width from 100 mm to 600 mm. The Adjustable Rigging Clamp is designed to be self adjusting to the flange thickness from as little as 3mm to as thick as 60 mm.

The Adjustable Rigging Clamp is designed to accommodate a safe working load not to exceeding 22.2 kN.

Product Code	Flange Width	Bolt Torque	Safe Working Load
	mm	Nm	kN
<b>BKRCM16-A</b>	100 to 200	150	22,2
<b>BKRCM16-B</b>	200 to 300	150	22,2
<b>BKRCM16-C</b>	300 to 400	150	22,2
<b>BKRCM16-D</b>	400 to 500	150	22,2
<b>BKRCM16-E</b>	500 to 600	150	22,2

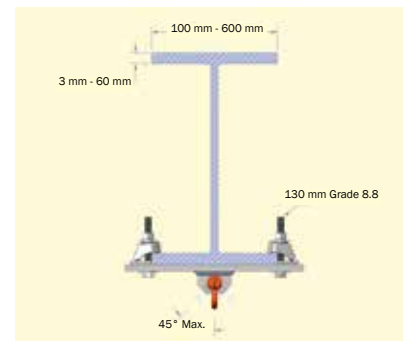
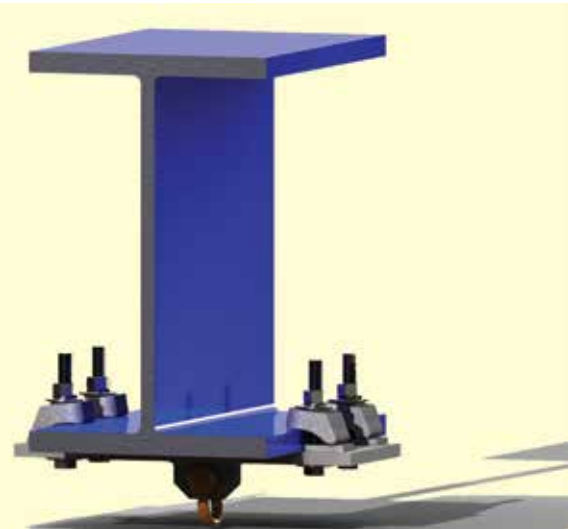

Note: The structural integrity of the existing steelwork should be verified by a licensed structural Engineer

## BeamClamp® Component Type BB Long Nose (BBLN)

The BB Long Nose is very similar to our standard type BB but with an extended nose. This distributes more contact on the flanges of parallel beams providing, contact closer to the web. Packing pieces BH1, BF1 and BG1 can be used with this product to make it fit to various thickness's of steel at 90 degrees, see page 24 for details.

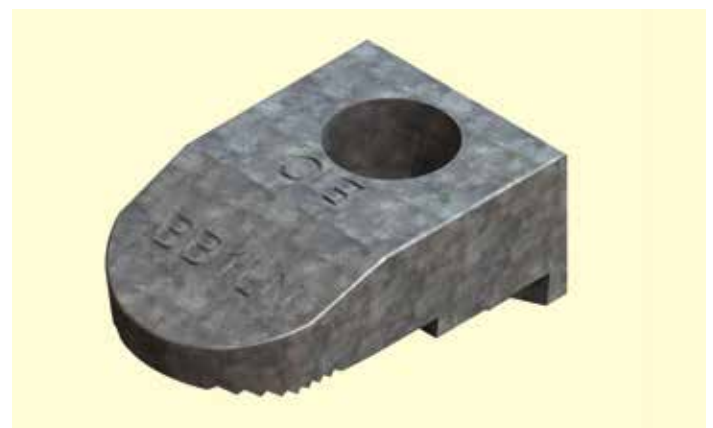

- Hot Dip Galvanised to BS EN ISO 1461
- Manufactured from Ductile Iron to BS EN 1563
- 5 to 1 Factor of Safety
- Independently tested

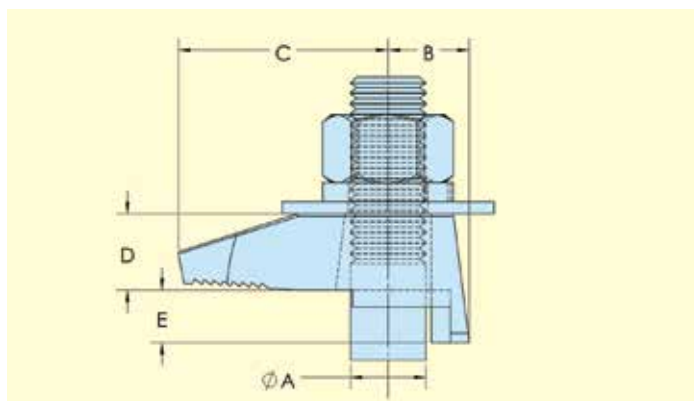

Product Code	Bolt Grade	A Bolt Dia.	B (mm)	C (mm)	D (mm)	E (mm)	Width (mm)	Torque (Nm)	Tensile SWL (kN) per bolt (5:1 Factor of Safety)	Frictional SWL (kN) per two bolts Painted Steel (2:1 Factor of Safety)
<b>BB1LNG12</b>	<b>8.8</b>	M12	14.0	46.0	17.5	6.5	28.5	69	5.75	1.28
<b>BB1LNG16</b>	<b>8.8</b>	M16	17.5	44.5	16	11.0	36.5	147	9.87	3.88

# BeamClamp® Components Type BY & BYP

The Type BY clamp is designed for High Friction and Tensile applications that exceed the capacities of the standard **BEAMCLAMP** products. It features a recessed top that prevents the head of the bolt from rotating during installation therefore requires the use of only one wrench. The Type BYP washer can be used to fill in the recess of the Type BY to provide a flat surface for a washer and nut. This also allows the Type BY clamps to be used together in beam to beam connections. The full width tail of the BY allows for use with slotted holes and the Type BY may also be used in unison with other **BEAMCLAMP** products for greater diversity in applications.

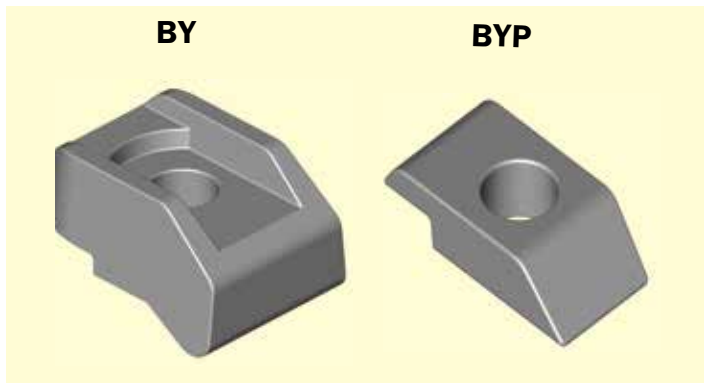

- Hot Dip Galvanised to BS EN ISO 1461.
- Manufactured from Ductile Iron to BS EN 1563.



These products are independently tested in situations to simulate typical site conditions.

Product Code	Product Grade	A Bolt Dia.	B (mm)	C (mm)	D1 (mm)	D2 (mm)	E		Width (mm)	Torque (Nm)	Tensile SWL (kN) per bolt (5:1 Factor of Safety)	Frictional SWL (kN) per two bolts Painted Steel (2:1 Factor of Safety)
							1 mm	2 mm				
BY G12	8.8	M12	27	28.5	13	23	5	12.5	40	90	11.65	4.29
BY G16	8.8	M16	33	33	17	30	8	15	49	240	19.41	8.02
BY G20	8.8	M20	39	39	22	37	10	18	55	470	32	11.94
BY G12	10.9	M12	27	28.5	13	23	5	12.5	40	130	11.65	7.88
BY G16	10.9	M16	33	33	17	30	8	15	49	300	19.41	15.50
BY G20	10.9	M20	39	39	22	37	10	18	55	647	32	23.76

Add "1" or "2" to the product code to indicate the desired tail length. For example, a M16 bolt diameter with 8mm tail would be code BY1G16.

\*Frictional failure for the Type BY clamp is 1mm slip from its original position.

Frictional capacities are based on shot blast and painted steelwork.

Due to variance in thickness of Hot Dip Galvanised coatings please contact Kee Safety for frictional capacities based on Hot Dip Galvanised steelwork.

Independently tested at Ceram and approved for use by Lloyd's Register.

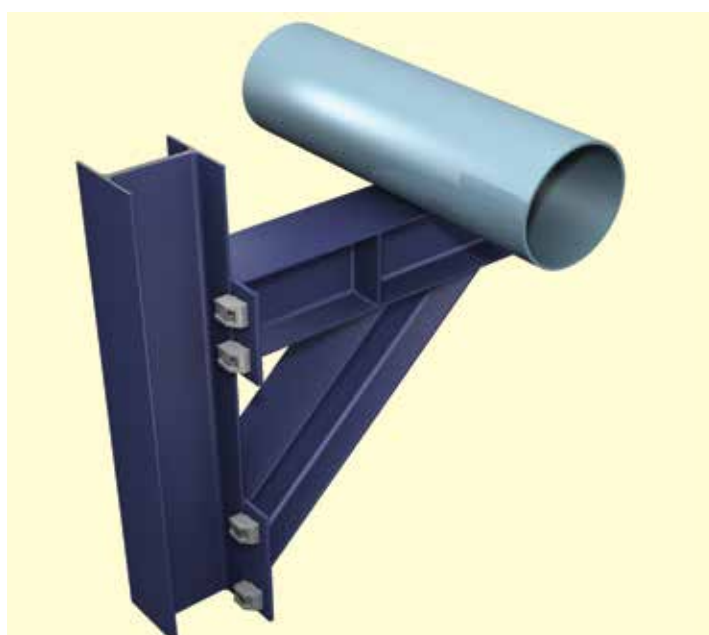
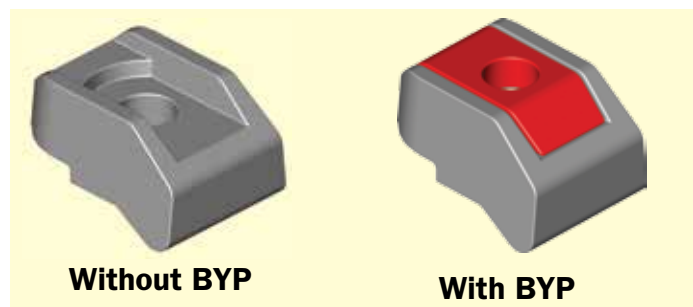
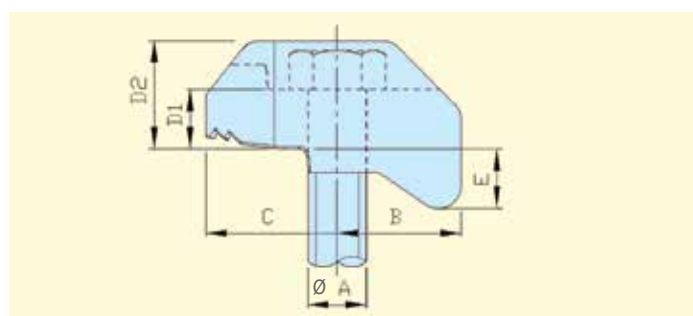

The BY recess is suitable for the hexagonal head of standard grade 8.8 and 10.9 bolts. The Type BYP may be used to fill in the recess allowing for any grade bolt or nut to be tightened down to its surface.

Typical end plate cantilevered connection supporting heavy duty pipe work.

# BeamClamp® Packing Pieces for BY Clamps

The range of packing pieces below are designed to provide support to the underside of type BY clamps to ensure they clamp at 90 degrees to the steel and provide a flat surface for the bolt head or nut to be tightened down on to. These can be used in various combinations with the two tail lengths of BY clamps to achieve the best clamping position.

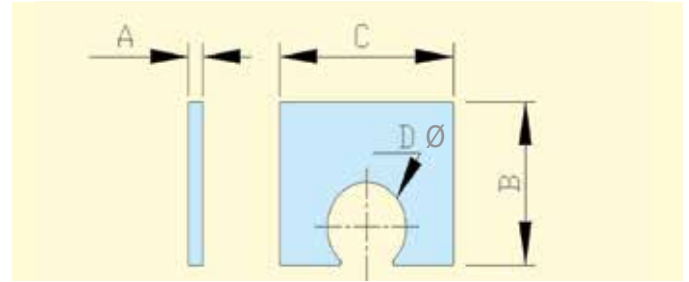

**Type BF3**



**Type BF4**

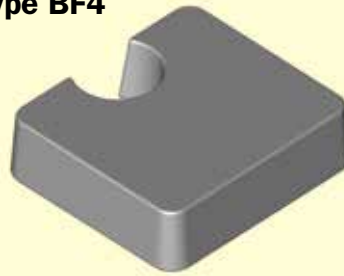

**Type BH2**

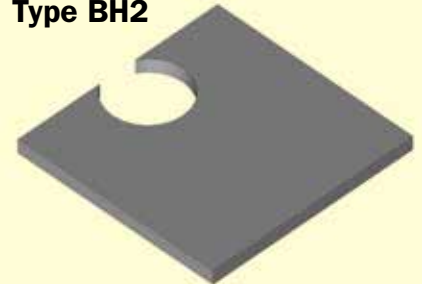

Product Code	A (mm)	B (mm)	C (mm)	Ø D (mm)
BF3G12	5	40	40	14
BF3G16	5	50	52	18
BF3G20	5	55	56	21

Product Code	A (mm)	B (mm)	C (mm)	Ø D (mm)
BF4G12	10	40	40	14
BF4G16	10	50	52	18
BF4G20	10	55	56	21

Product Code	A (mm)	B (mm)	C (mm)	Ø D (mm)
BH2G12	2	40	40	14
BH2G16	2	48	48	18
BH2G20	2	50	50	21

The Type BY can be used in a variety of applications and our design team will be pleased to configure a connection specific to your requirements. Please see pages 30 to 31 for packing and tail length combinations, and page 29 for location plate and bolt length details.

## Type BY Typical Applications

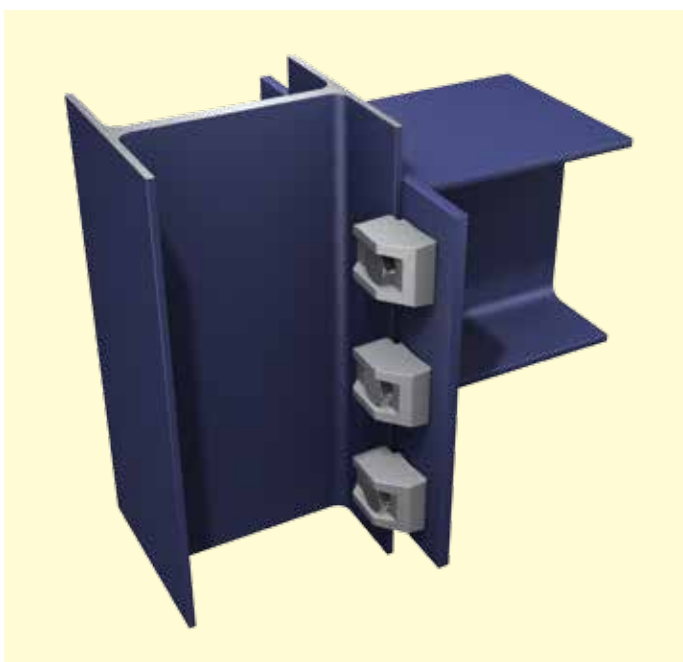

Typical End Plate frictional connection using BY clamps.

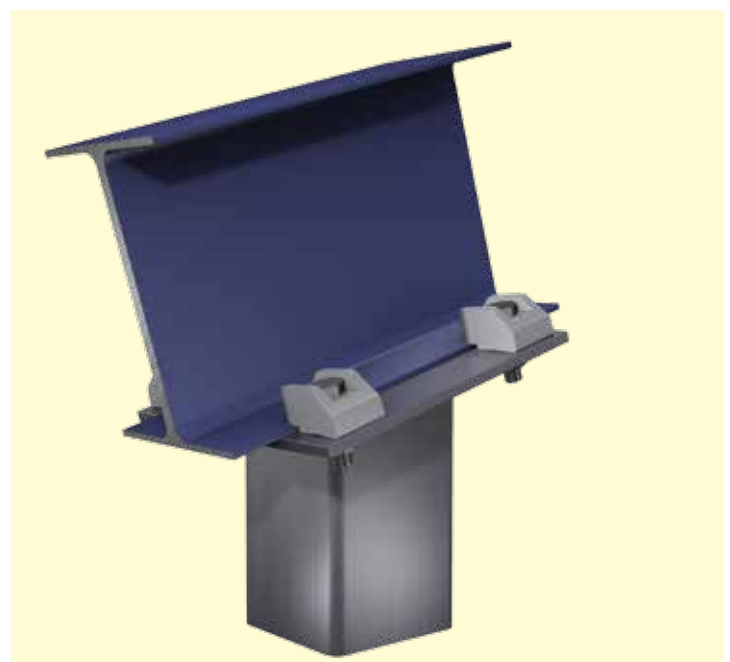

Typical sloping beam connection using BY clamps.



# BeamClamp® Type BY - Location Plate & Spacers

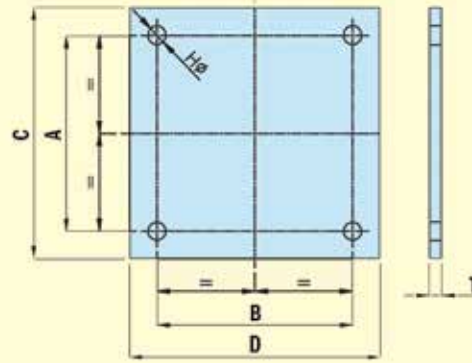
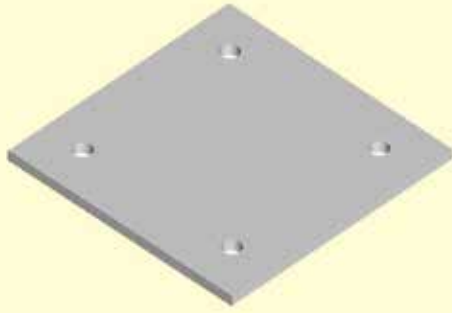

## Location Plate Dimensions for Type BY

Bolt dia.	Bolt Grade	A (mm)	B (mm)	C (mm)	D (mm)	H (mm)	T (mm)
		Upper Beam Width	Lower Beam Width	Upper Beam Width	Lower Beam Width	Diameter	Min.
M12	8.8	14	14	95	95	14	12
M12	10.9	14	14	95	95	14	12
M16	8.8	18	18	118	118	18	15
M16	10.9	18	18	118	118	18	15
M20	8.8	22	22	127	127	22	20
M20	10.9	22	22	127	127	22	25

Note: Cap/End plate thickness will vary based on the design code followed, the flange width of the applicable beam and the type of load acting on the connection. Please contact a structural engineer for further details.

## Thickness of Clamps

Bolt dia.	Type BY (X)	Type BY + BYP (X)
M12	13	23
M16	17	30
M20	22	37

## Thickness of Nut & Washer

Bolt dia.	N
M12	12
M16	16
M20	22

## Bolt Length Calculation

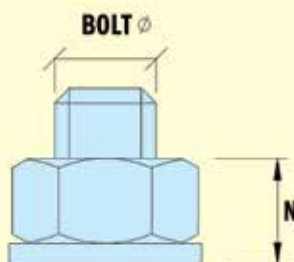
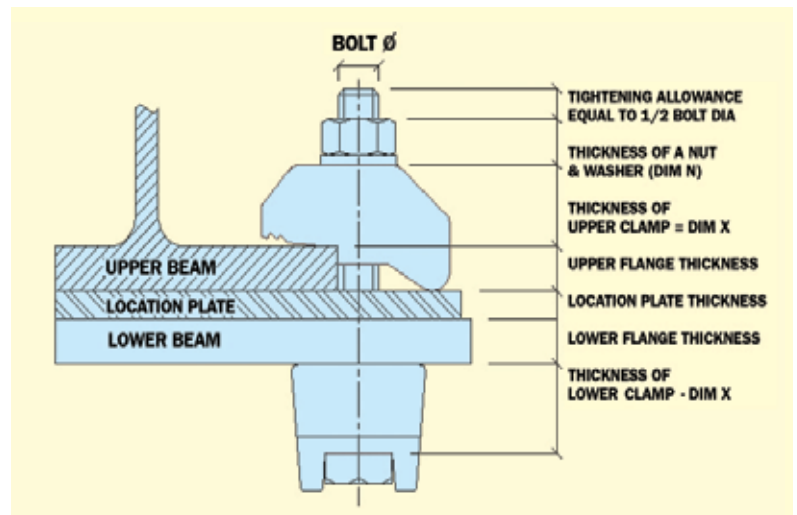

## Location Spacers

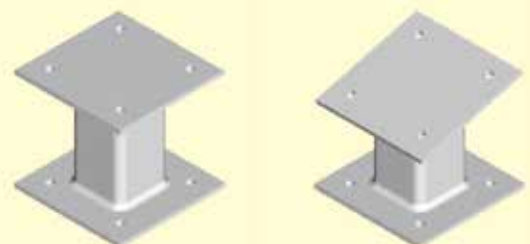

**Table 1 For Parallel Beams up to and including 5° slope**

Flange thickness (mm)	M08		M10			M12			
	BA & BB	BK1	BA & BB	BE1	BK1	BA & BB	BY	BE1 & BE2	BK1
4	2	OK	1	X	OK	X	X	X	OK
5	2	OK	2	OK	OK	1	1	OK	OK
6	2+BH1	OK	1+BH1	OK	OK	2	1	OK	OK
7	2+BH1	OK	3	OK	OK	1+BH1	1+BH2	OK	OK
8	2+BF1	OK	1+2BH1	OK	OK	2+BH1	1+BH2	OK	OK
9	2+BF1	OK	1+BF1	OK	OK	2+BH1	1+2BH2	OK	OK
10	2+BH1+BF1	OK	2+BF1	OK	OK	3	1+BF3	OK	OK
11	2+BH1+BF1	OK	3+2BH1	OK	OK	2+2BH1	1+3BH2	OK	OK
12	2+BG1	OK	3+BF1	OK	OK	3+BH1	1+BH2+BF3	OK	OK
13	2+BG1	+BF2	3+3BH1	OK	OK	1+BH1+BF1	2	OK	OK
14	2+BH1+BG1	+BF2	1+BG1	OK	OK	2+BF1+BH1	2+BH2	OK	OK
15	2+BH1+BG1	+BF2	2+BG1	OK	OK	2+BF1+BH1	1+BF4	OK	OK
16	2+BF1+BG1	+BF2	1+BH1+BG1	OK	+BF2	3+BF1	2+2BH2	OK	OK
17	2+BF1+BG1	+BG2	3+BG1	OK	+BF2	2+2BH1+BF1	2+BF3	OK	OK
18	2+BH1+BF1+BG1	+BG2	1+2BH1+BG1	OK	+BF2	2+BG1	2+BF3	OK	OK
19	2+BH1+BF1+BG1	+BG2	1+BF1+BG1	OK	+BF2	1+BH1+BG1	2+BH2+BF3	OK	+BF2
20	2+2BG1	+BG2	2+BF1+BG1	OK	+BF2	1+BH1+BG1	1+BF3+BF4	OK	+BF2
21	2+2BG1	+BF2+BG2	3+2BH1+BG1	+BF2	+BG2	3+BF1+2BH1	2+2BH2+BF3	OK	+BF2
22	2+BH1+2BG1	+BF2+BG2	3+BF1+BG1	+BF2	+BG2	3+BG1	2+2BH2+BF3	OK	+BF2
23	2+BH1+2BG1	+BF2+BG2	3+BF1+BG1	+BF2	+BG2	2+2BH1+BG1	2+BF4	+BF2	+BF2
24	2+BF1+2BG1	+BF2+BG2	1+2BG1	+BF2	+BG2	2+BF1+BG1	2+BH2+BF4	+BF2	+BF2
26	2+BH1+BF1+2BG1	+2BG2	1+BH1+2BG1	+BG2	+BF2+BG2	3+2BH1+BG1	2+2BH2+BF4	+BF2	+BG2
28	2+3BG1	+2BG2	3+2BG1	+BG2	+BF2+BG2	3+BF1+BG1	2+BF3+BF4	+BF2	+BG2
30	2+BH1+3BG1	+BF2+2BG2	2+BF1+2BG1	+BG2	+BF2+BG2	2+2BG1	1+BF3+2BF4	+BG2	+BG2

**Table 2 For Beams with 5° to 8° slope**

Flange thickness (mm)	M08		M10		M12			M16		
	BA & BB	BK1	BA & BB	BK1	BA & BB	BY	BK1	BA & BB	BY	BK1
4	X	OK	X	OK	X	X	OK	X	X	OK
5	2	OK	1	OK	X	1	OK	X	X	OK
6	2	OK	2	OK	1	1	OK	X	X	OK
7	2+BH1	OK	1+BH1	OK	2	1+BH2	OK	1	1	OK
8	2+BH1	OK	3	OK	1+BH1	1+BH2	OK	1	1	OK
9	2+BF1	OK	1+2BH1	OK	2+BH1	1+2BH2	OK	2	1	OK
10	2+BF1	OK	3+BH1	OK	2+BH1	1+BF3	OK	1+BH1	1+BH2	OK
11	2+BH1+BF1	OK	2+BF1	OK	3	1+3BH2	OK	1+BH1	1+BH2	OK
12	2+BH1+BF1	OK	3+2BH1	OK	2+2BH1	1+BH2+BF3	OK	3	1+2BH2	OK
13	2+BG1	+BF2	3+BF1	OK	3+BH1	2	OK	1+2BH1	1+BF3	OK
14	2+BG1	+BF2	3+3BH1	OK	1+BF1+BH1	2+BH2	OK	1+2BH1	1+3BH2	OK
15	2+BH1+BG1	+BF2	1+BG1	OK	3+2BH1	1+BF4	OK	1+BF1	2	OK
16	2+BH1+BG1	+BF2	2+BG1	+BF2	2+BF1+BH1	2+2BH2	OK	1+3BH1	2	OK
17	2+BF1+BG1	+BG2	1+BH1+BG1	+BF2	1+BG1	2+BF3	OK	1+3BH1	2+BH2	OK
18	2+BF1+BG1	+BG2	3+BG1	+BF2	2+2BH1+BF1	2+BF3	OK	1+BH1+BF1	1+BF4	OK
19	2+BH1+BF1+BG1	+BG2	1+2BH1+BG1	+BF2	2+BG1	2+BH2+BF3	+BF2	3+2BH1	2+2BH2	OK
20	2+BH1+BF1+BG1	+BG2	3+BH1+BG1	+BF2	1+BH1+BG1	1+BF3+BF4	+BF2	3+2BH1	2+BF3	OK
21	2+2BG1	+BF2+BG2	2+BF1+BG1	+BG2	1+BH1+BG1	2+2BH2+BF3	+BF2	1+2BH1+BF1	2+BF3	OK
22	2+2BG1	+BF2+BG2	3+2BH1+BG1	+BG2	2+BH1+BG1	2+2BH2+BF3	+BF2	3+3BH1	2+BH2+BF3	OK
23	2+BH1+2BG1	+BF2+BG2	3+BF1+BG1	+BG2	3+BG1	2+BF4	+BF2	1+BG1	2+BH2+BF3	OK
24	2+BH1+2BG1	+BF2+BG2	1+2BH1+BF1+BG1	+BG2	2+2BH1+BG1	2+BH2+BF4	+BF2	3+BH1+BF1	2+BF4	OK
26	2+BF1+2BG1	+2BG2	2+2BG1	+BF2+BG2	1+BH1+BF1+BG1	2+2BH2+BF4	+BG2	1+BH1+BG1	2+BF4	+BF2
28	2+BH1+BF1+2BG1	+2BG2	3+2BG1	+BF2+BG2	3+2BH1+BG1	2+BF3+BF4	+BG2	3+2BH1+BF1	1+2BF4	+BF2
30	2+3BG1	+BF2+2BG2	3+BH1+2BG1	+BF2+BG2	3+3BH1+BG1	1+BF3+2BF4	+BG2	3+2BH1+BG1	2+BF3+BF4	+BF2

Instruction how to use these tables, when specifying the correct BEAMCLAMP product, are on page 32.

# BeamClamp® Product Selection Tables

Flange thickness (mm)	M16				M20				M24		
	BA & BB	BY	BE1 & BE2	BK1	BA & BB	BY	BE1	BK1	BA & BB	BE1	BK1
4	X	X	X	OK	X	X	X	OK	X	X	OK
5	1	X	X	OK	X	X	X	OK	X	X	OK
6	1	X	X	OK	1	X	X	OK	X	X	OK
7	1	1	OK	OK	1	X	X	OK	X	X	OK
8	2	1	OK	OK	1	X	OK	OK	1	X	OK
9	1+BH1	1	OK	OK	2	1	OK	OK	1	X	OK
10	1+BH1	1+BH2	OK	OK	2	1	OK	OK	1	OK	OK
11	3	1+BH2	OK	OK	1+BH1	1	OK	OK	2	OK	OK
12	1+2BH1	1+2BH2	OK	OK	1+2BH1	1+BH2	OK	OK	2	OK	OK
13	1+BF1	1+BF3	OK	OK	3	1+BH2	OK	OK	1+BH1	OK	OK
14	3+BH1	1+3BH2	OK	OK	2+BH1	1+2BH2	OK	OK	1+BH1	OK	OK
15	1+3BH1	2	OK	OK	1+2BH1	1+BF3	OK	OK	3	OK	OK
16	2+BF1	2	OK	OK	3+BH1	1+3BH2	OK	OK	3	OK	OK
17	3+2BH1	2+BH2	OK	OK	1+BF1	2	OK	OK	1+2BH1	OK	OK
18	3+2BH1	1+BF4	OK	OK	2+2BH1	2	OK	OK	1+2BH1	OK	OK
19	3+BF1	2+2BH2	OK	OK	1+3BH1	2	OK	OK	3+BH1	OK	OK
20	3+3BH1	2+BF3	OK	OK	2+BF1	2+BH2	OK	OK	3+BH1	OK	OK
21	3+3BH1	2+BF3	OK	OK	1+BH1+BF1	2+BH2	OK	OK	1+BF1	OK	OK
22	3+BH1+BF1	2+BH2+BF3	OK	OK	2+3BH1	2+2BH2	OK	OK	1+BF1	OK	OK
23	3+BH1+BF1	2+BH2+BF3	OK	OK	3+BF1	2+BF3	OK	OK	2+BF1	OK	OK
24	2+BG1	2+BF4	+BF2	OK	2+BH1+BF1	2+BF3	OK	OK	2+BF1	OK	OK
26	3+2BH1+BF1	2+BF4	+BF2	+BF2	1+2BH1+BF1	2+BH2+BF3	+BF2	OK	1+BH1+BF1	OK	OK
28	1+2BH1+BG1	1+2BF4	+BF2	+BF2	2+2BH1+BF1	2+BF4	+BF2	OK	3+BF1	OK	OK
30	3+BH1+BG1	2+BF3+BF4	+BF2	+BF2	2+BG1	2+BH2+BF4	+BF2	OK	3+BF1	OK	OK

Table 3 For Beams with 8° to 10° slope

Flange thickness (mm)	M20			M24	
	BA & BB	BY	BK1	BA & BB	BK1
4	X	X	OK	X	OK
5	X	X	OK	X	OK
6	X	X	OK	X	OK
7	X	X	OK	X	OK
8	X	X	OK	X	OK
9	1	1	OK	X	OK
10	1	1	OK	1	OK
11	2	1	OK	1	OK
12	2	1+BH2	OK	1	OK
13	1+BH1	1+BH2	OK	1	OK
14	3	1+2BH2	OK	2	OK
15	3	1+BF3	OK	2	OK
16	2+BH1	1+3BH2	OK	1+BH1	OK
17	1+2BH1	2	OK	1+BH1	OK
18	3+BH1	2	OK	3	OK
19	1+BF1	2	OK	3	OK
20	2+2BH1	2+BH2	OK	1+2BH1	OK
21	1+3BH1	2+BH2	OK	1+2BH1	OK
22	2+BF1	2+2BH2	OK	3+BH1	OK
23	1+BH1+BF1	2+BF3	OK	3+BH1	OK
24	2+3BH1	2+BF3	OK	3+BF1	OK
26	2+BH1+BF1	2+BH2+BF3	OK	2+BF1	OK
28	1+2BH1+BF1	2+BF4	OK	1+BH1+BF1	OK
30	2+2BH1+BF1	2+BH2+BF4	OK	3+BF1	OK

Flange thickness (mm)	M12	M16	M20
	BT oder BW	BT oder BW	BT oder BW
4	1	X	X
5	1	X	X
6	2	1	X
7	1+BH1	1	1
8	2+BH1	2	1
9	1+2BH1	1+BH1	1
10	1+BF1	1+BH1	2
11	2+2BH1	2+BH1	1+BH1
12	2+BF1	1+BF1	1+BH1
13	1+BH1+BF1	1+BF1	2+BH1
14	2+BH1+BF1	1+BF1	2+BH1
15	2+BH1+BF1	1+3BH1	1+2BH1
16	1+BG1	2+BF1	1+2BH1
17	2+2BH1+BF1	1+BH1+BF1	1+BF1
18	2+BG1	1+BH1+BF1	2+2BH1
19	1+BH1+BG1	2+BH1+BF1	1+3BH1
20	2+BH1+BG1	1+2BH1+BF1	2+BF1
21	2+BH1+BG1	1+2BH1+BF1	2+BF1
22	1+BF1+BG1	1+BG1	2+3BH1
23	1+BF1+BG1	1+3BH1+BF1	2+3BH1
24	2+BF1+BG1	2+BG1	2+BH1+BF1
26	2+BH1+BF1+BG1	1+BH1+BG1	1+BG1
28	1+2BG1	2+BH1+BG1	1+3BH1+BF1
30	2+2BG1	1+BF1+BG1	2+BG1



# Specifying the Correct BeamClamp® Product

Correct product specification stating type, size and tail length together with packing piece combinations are essential to achieve a safe fixing solution. However before creating a **BEAMCLAMP** bill of materials the following information is required:

- 1) Diameter of fixings or the required Safe Working Load (SWL) of the connection**
- 2) Details of the steel sections being connected**

Types **BA/BB & BT/BW** are the most economic solutions when beam

details are known. **Types BK, BE1 & BE2** are solutions when beam details are unknown, these adjustable types require a check to ensure that the maximum clamping thickness has not been exceeded; if it has then reference to the tables are necessary to choose the correct packing pieces.

Tables on pages 30 and 31 in conjunction with the Safe Working Loads (SWL) stated in the individual product pages assist this selection without using calculations. Dimensions and section properties can be obtained from Steelwork Dimensions pages 50 and 51 or Structural Steel Handbooks.

## Example

What products are required when using a **M12** bolt to connect two different steel sections together?  
Top flange = 7mm thick (**BA**), Bottom flange = 9mm thick (**BB**)

Refer to adjacent Table 1 extracts

Select Flange Thickness

Select Clamp Type

Select Bolt Diameter

**Top Section Solution**

- 1) Select bolt diameter (**M12**)
- 2) Select Clamp type (**BA**)
- 3) Select Flange thickness (**7**)

**ANSWER**

**1 No. BA1 G12**  
**1 No. BH1 Z12**

Flange (t) mm	M12			M16		
	BA or BB	BK1	BK1	BA or BB	BE1	BK1
4	X	X	OK	X	X	OK
5	1	OK	OK	1	X	OK
6	2	OK	OK	1	X	OK
7	<b>1+BH1</b>	OK	OK	1	OK	OK
8	2+BH1	OK	OK	2	OK	OK
9	2+BH1	OK	OK	1+BH1	OK	OK
10	3	OK	OK	1+BH1	OK	OK

Select Flange Thickness

Select Clamp Type

Select Bolt Diameter

**Bottom Section Solution**

- 1) Select bolt diameter (**M12**)
- 2) Select Clamp type (**BB**)
- 3) Select Flange thickness (**9**)

**ANSWER**

**1 No. BB2 G12**  
**1 No. BH1 Z12**

Flange (t) mm	M12			M16		
	BA or BB	BK1	BK1	BA or BB	BE1	BK1
4	X	X	OK	X	X	OK
5	1	OK	OK	1	X	OK
6	2	OK	OK	1	X	OK
7	1+BH1	OK	OK	1	OK	OK
8	2+BH1	OK	OK	2	OK	OK
9	<b>2+BH1</b>	OK	OK	1+BH1	OK	OK
10	3	OK	OK	1+BH1	OK	OK

# FastFit® System

The **FASTFIT** product has been designed to connect steel sections together without the need for drilling, welding or the need to make special location plates/brackets. The tables below demonstrate the time that can be saved by using the **FASTFIT** system when compared to a standard welded or bolted connection.

The majority of the time and cost is saved by the reduction in preparation and labour time. This model does not include potential for remedy work that may need to be carried out should the connection not be in the correct place. The **FASTFIT** system allows for quick and easy relocation of the connection provided the beams are fully supported.



## FASTFIT SYSTEM vs. DRILLING & WELDING

Connection Requirements	Time (hrs)	Details of each step
Engineering	0.1	The design time is reduced dramatically as the system works within stated parameters
Marking of steel	0.05	The marking is reduced as the connection is adjustable
Site set up	0.05	Product arrives in a kit ready to install
Assembly time	0.05	The assembly time is quicker than a bolted connection as no hole alignment is required
Tightening of bolts	0.04	Allowing 1 minute per bolt and nut
<b>Approx. 30 min</b>		

## WELDED

Using a fully filleted weld connecting to red oxide or galvanised steel.

Connection Requirements	Time (hrs)	Details of each step
Engineering	0.25	Limited design work required apart from highlighting the position and penetration of weld
Apply for hot work permit	0.5	The issue time is set at 30 min which can be much longer
Marking of steel	0.25	The marking of the steel is minimum for a welded connection
Site set up	0.5	Time to move equipment, power cords and get machinery ready
Removal of corrosion protection	1	The whole area for the weld needs to be removed by grinding and is time consuming
Performing of weld (including equipment)	1.5	Based on a coded welder and equipment to make the connection
Touch up of Galv / Paint	0.33	Replacement of the galv/paint will not be as good as the original finish
Non destructive testing	0.33	Testing of the weld required to prove load capabilities
<b>Approx. 4.5 hrs</b>		

## TIME IS MONEY

Welding (hrs)	Drilling & Bolting (hrs)	FastFit (hrs)	Savings (hrs)
4.5	3.5	0.5	3 to 4

## DRILLING AND BOLTING

Using M16 Grade 8.8 High tensile Bolts.

Connection Requirements	Time (hrs)	Details of each step
Engineering	0.25	Detailing the positions and checking the integrity of the existing steel after adding holes
Drilling time of new steel off site	1	Based on a flange thickness of 12 mm and 1/4 hr per hole (see cutting speed rates)
Marking of steel	0.25	The time required to mark the steel on site to ensure alignment with secondary member
Site set up	0.5	The time required to access power, get the drilling machine into position etc.
Drilling time on site	1	Based on a flange thickness of 12 mm and 1/4 hr per hole (see cutting speed rates)
Positioning and alignment	0.5	Alignment of Primary and secondary steel holes on site
Assembly time	0.05	Very quick to assemble with only four bolts and nuts once steel is aligned
Tightening of bolts	0.04	Allowing 1 minute per bolt and nut
<b>Approx. 3.5 hrs</b>		

# FastFit® Connection System Type BCFF16

**FASTFIT** is an off the shelf engineered clamping solution to connect two steel sections together without the need for on-site drilling or welding. All you need to secure two sections together comes in one box. The system comprises a frame which wraps around the edges of the sections and slides into place to provide a position for the clamps to be secured.

The system allows for varying angles that can be easily achieved by sliding the beams relative to each other.

The **FASTFIT** system delivers a guaranteed connection every time without the need for on-site testing or relying on the skills of the installer. No removal of the protective coatings on the existing steel or holes is needed to make a connection. All that is required to complete a connection are simple hand tools and semi-skilled labour.



## Why use FastFit® and what benefits does it provide?

Features	Advantages	Benefits
<b>No drilling or welding to existing structure</b>	No on-site power required	Reduced installation time and no need to relocate cables, hoses etc.
<b>Clamps directly to the existing structure</b>	No damage to corrosion protection and no weakening of the steel	The structure retains its original strength and life expectancy
<b>No heat or sparks generated</b>	No hot work permit is necessary	Reduction in installation cost and administration time
<b>No additional safety considerations</b>	Safe for use in hazardous conditions	Peace of mind that the connection can be made without any hazards being created
<b>Installation by semi-skilled labour</b>	No need for specialist skills or equipment	Reduction in labour and hire costs
<b>Easy realignment of steel members</b>	Eliminates remedial work due to steel misalignment	Reduction in labour costs and provides on site flexibility
<b>Tested at a third party test facility</b>	Third party tested for use in tensile and frictional applications	Confidence that the connection will perform as stated in the literature
<b>Electro Galvanised Finish</b>	Corrosion protection is provided as standard meaning no post touch up or finish	Reduction in installation time and confidence in the finish
<b>Suits a wide range of steel sections</b>	A one stop shop for most connections	Reduced sourcing costs for users
<b>Guaranteed loading and factor of safety</b>	No on-site testing required or reliance on the skill of the installer	Reduction in installation time and peace of mind that every connection will perform as stated
<b>Flush steel to steel connection</b>	No location plate or spacers required	Saves time on re-design due to height level changes

# Technical Information

Product Code	Bolt dia.	Bolt grade	Bolt length (mm)	Overall size (mm)	Flange thickness (mm)	Flange width (mm)	Tightening torque (Nm)	Tensile load (4 bolts) (kN)	Frictional load (4 bolts) (kN)
BCFF16	M16	8.8	130	350 x 350	3 to 27	65 to 190	150	21.19	5.08

## Factor of Safety

The above loading data has a 5 to 1 Factor of Safety.

## Achievable Angles

The **FASTFIT** system is designed to allow sections of different widths to be connected at varying angles. The table below provides information on the angles which can be achieved.

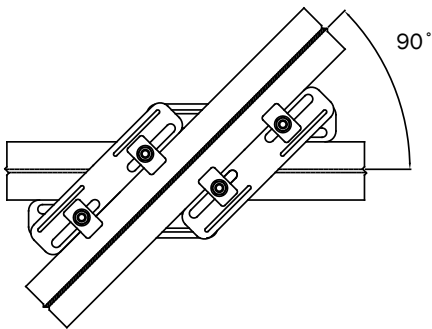

mm	Top Section Flange Width											
	65	76.2	88.9	101.6	114.3	127.0	139.7	152.4	165.1	177.8	190	
65	45	45	50	50	50	55	55	60	65	70	75	
76.2	45	45	50	50	50	55	55	60	65	70	75	
88.9	50	50	50	50	55	55	55	55	65	70	75	
101.6	50	50	50	50	55	55	55	55	65	70	75	
114.3	50	50	50	50	50	55	55	55	65	70	75	
127.0	55	55	55	55	55	55	55	55	65	70	75	
139.7	55	55	55	55	55	55	55	55	65	70	75	
152.4	60	60	60	60	60	60	60	65	65	70	75	
165.1	65	65	65	65	65	65	65	65	65	70	75	
177.8	70	70	70	70	70	70	70	70	70	75	75	
190	75	75	75	75	75	75	75	75	75	75	80	

## Installation Instructions

The **FASTFIT** system can be fully installed in under 5 minutes which saves time compared to traditional welding or drilling methods. Following the steps below will give a fully guaranteed connection.

**STEP 1** - Install the framework of plates around the two sections to be connected.



**STEP 2** - Rotate the open side of the plate around the sections so that the frame is complete.



**STEP 3** - Insert one set of clamps through each corner ensuring they are positioned as in step 4.



**STEP 4** - The front and back edge of the clamps should run parallel with the steel sections.



**STEP 5** - Hold the head of the bolt with a standard wrench and tighten the nut with a torque wrench to the recommended torque stated above. Repeat this for all four bolts.



**IMPORTANT CHECK!**  
Always check the clamps have been installed the correct way around. See diagrams below:

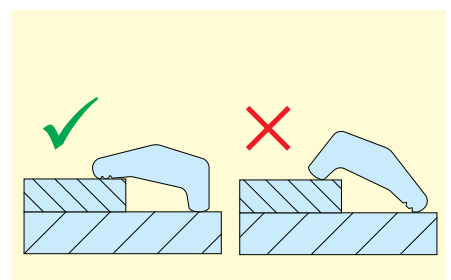



# Safe Fixing Solutions

## Typical BeamClamp® Assembly

The diagram to the left is an example of a typical **BEAMCLAMP** assembly used to connect two steel sections together. The assembly consists of a pre-drilled location plate inserted between the two steel sections. An upper set of **BEAMCLAMP** components clamp down on the lower flange of the upper beam while a lower set of components work in the opposite direction, clamping the underside of the upper flange of the lower member. Additional packing shims may be used to adjust the clamp to the thickness of the flange being connected. The connection is secured by inserting a bolt through each of the lower clamps, the location plate, the upper clamps and then tightening a nut to the recommended torque. **BEAMCLAMP** is pleased to offer a free design service to advise on the appropriate components for your particular assembly. In addition, we are pleased to include a quotation for your supply of bolts, nuts, washers and predrilled location plates.

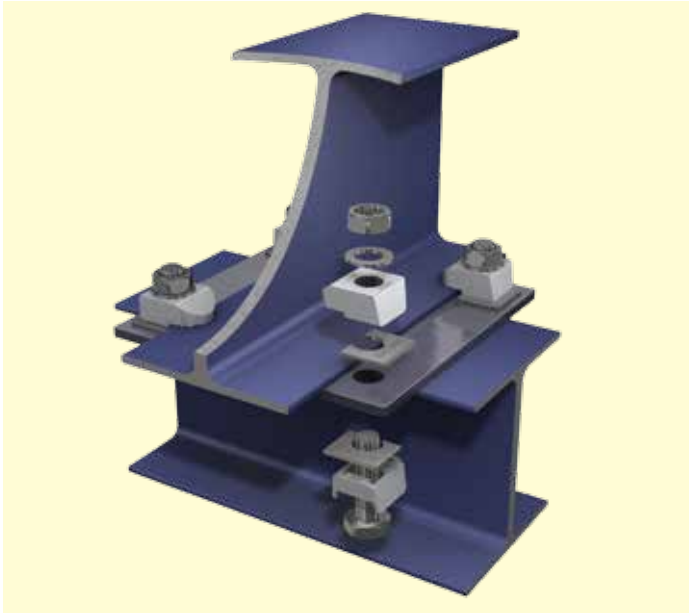

10



Two I-Sections of equal width running parallel

11



Two I-Sections at 90 degrees to each other using a location spacer bracket

12



Two I-Sections at 90 degrees with a sloping top beam using two location plates

13

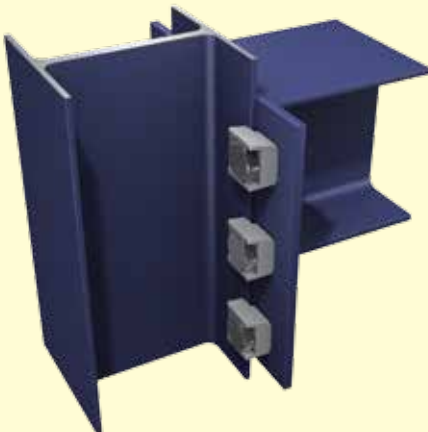

I-Section with end plate to column at 90 degrees

14



I-Section to I-Section with an angled cross over

15

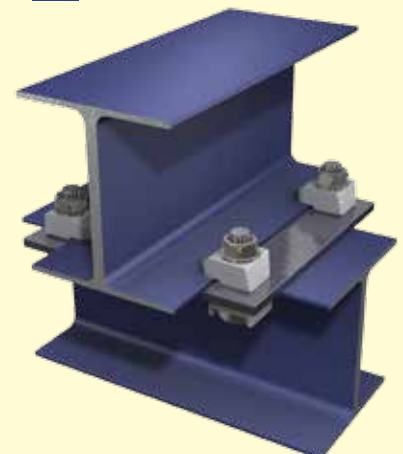

I-Section to I-Section at 90 degrees to each other

# Safe Fixing Solutions

16

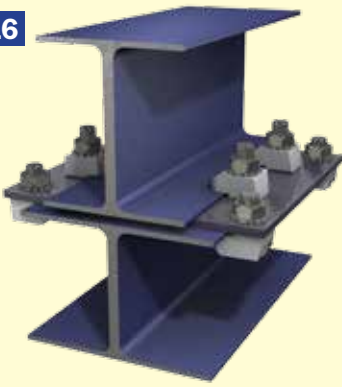

I-Sections of different widths running parallel

17



I-Section to top of a column end plate

18



Sloping I-section with a gap to another I-section using a spacing bracket

19



Two I-Sections at 90 degrees with a gap between using threaded bar and location plates

20

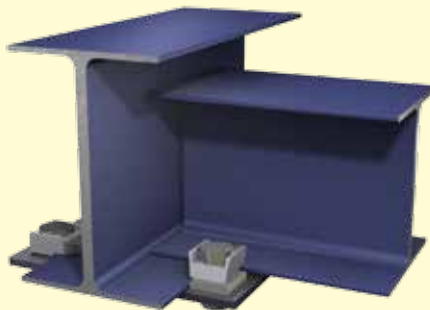

I-Section secured to the inside flange of another I-Section

21



Column end plate to sloping I-Section

22

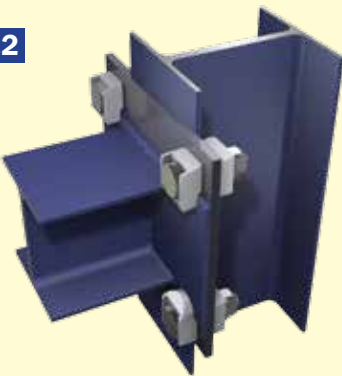

I-Section to I-Section column using a location plate

23



Heavy duty pipe support to I-Section

24

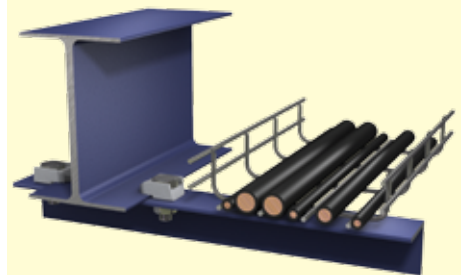

Cantilevered angle support to I-Section

25



Drilled I-Section running parallel to another I-Section

26



Fixed rigging point below an I-Section

27



Swivel rigging point below an I-Section

# Safe Fixing Solutions

28



Column end plate to I-Section

29

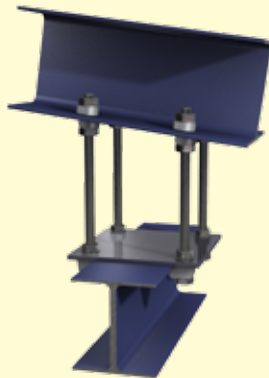

Hemispherical cup/washer hanging an I-Section underneath a sloping section

30



Hollow section below an I-Beam at 90 degrees using a combination of BoxBolt and BeamClamp fixings

31

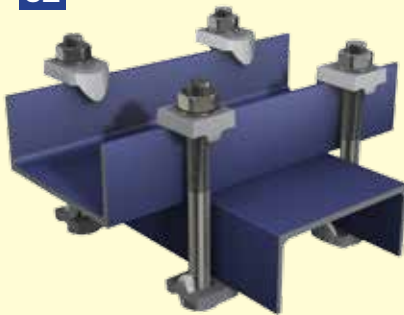

Two channels secured back to back

32



Angle section below an I-Section at 90 degrees

33



Channel section secured above an I-Section using two location plates

34



Channel section at 90 degrees below an I-Section

35



Channel section underneath another channel section at 90 degrees

36

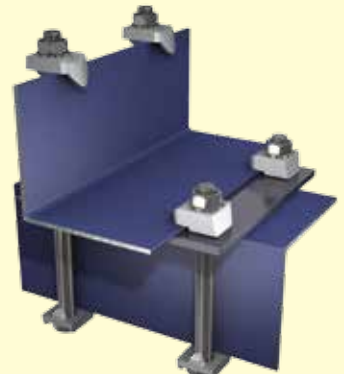

Angle section to another angle section at 90 degrees

37



Channel section below I-Section at 90 degrees

38



Channel section face upwards below I-Section at 90 degrees

39

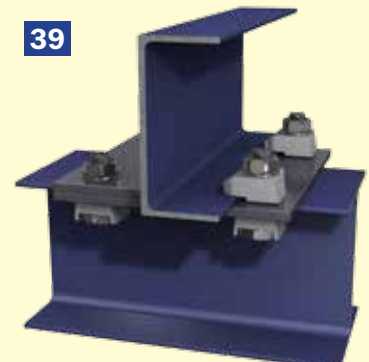

Channel positioned above I-Section at 90 degrees

# Steel Floor Fixings

## FloorFix HT



**THE FLOORFIX HT** has been developed following customer feedback to provide a fixing with increased functionality to suit a wider range of applications. **FLOORFIX HT** is designed to fix flooring plate to supporting steelwork from the topside only without the need for time consuming on site drilling, tapping, bolting or welding. It works on a cam mechanism that can be operated using a basic hexagon key drive.

- Allows for +/- 6mm construction tolerance
- Can fix up to 25mm thick steel as standard
- Hot Dip Galvanised finish as standard
- Easily installed from the top side only
- No drilling, no tapping or welding required
- Allows easy repositioning or lifting of floor plate
- No special tools or skilled labour required
- No access to the underside required
- Tested for vibration conditions at TÜV

**FLOORFIX HT** is so named because it allows steel erectors a high degree of tolerance, it retains all the benefits of our widely renowned original design but is far more user friendly. **FLOORFIX HT** allows for floor plates to be fixed to new steelwork that is erected within +/- 6mm of its intended position. It is capable of fixing to steel flanges from 3 to 25mm without the need for additional packing pieces.

## Plate Preparation

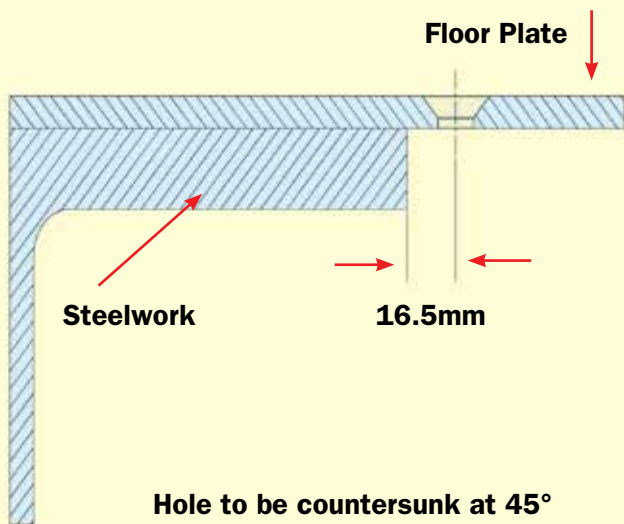

Product code	Screw dia	Floor Plate Thickness		Steelwork Flange Thickness		Tightening torque (Nm)
		min	max	min	max	
FloorFix M08HT	M08	3	12	3	25	20
FloorFix M10HT	M10	5	12	3	25	25
FloorFix M12HT	M12	6	12	3	25	30

**FLOORFIX HT** has been tested for vibration conditions to simulate the most common applications where the fixings would be used e.g. **walkways, machine shops** and **press shops**. Please ask our technical department for a copy of the certificate should you require this.



# FloorFix HT Installation Instructions

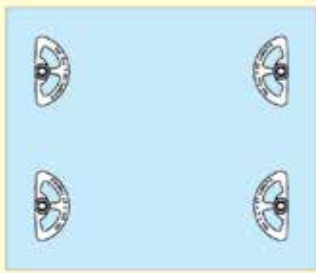

**Step 1** Assemble the **FLOORFIX HT** to the underside of the floor plate making sure the markings “**THIS WAY UP**” are facing the underside. Loosely tighten the bolt making sure the flat edge of the fixing is in line with the edge of the steelwork it is going to fix to.

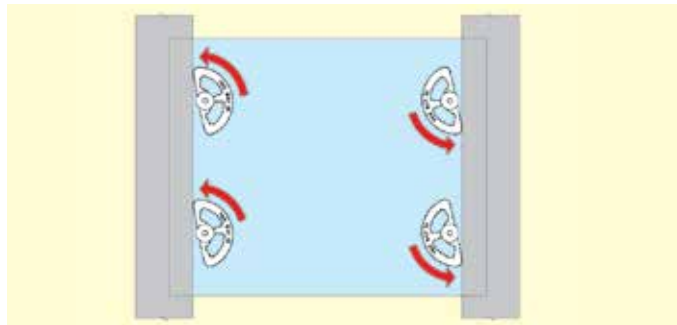

**Step 3** Once the floor plate is in the desired position rotate the countersunk bolt one full turn anti-clockwise.

**Note 1** We would recommend using the M12 version when vibration conditions are incurred as this can be tightened to a higher torque.

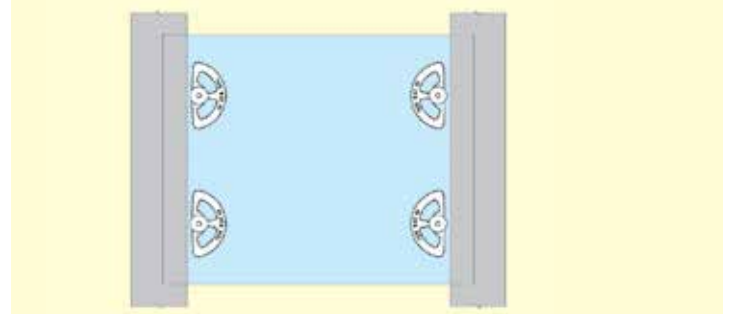

**Step 2** Lower the plate in to position over the supporting steelwork.

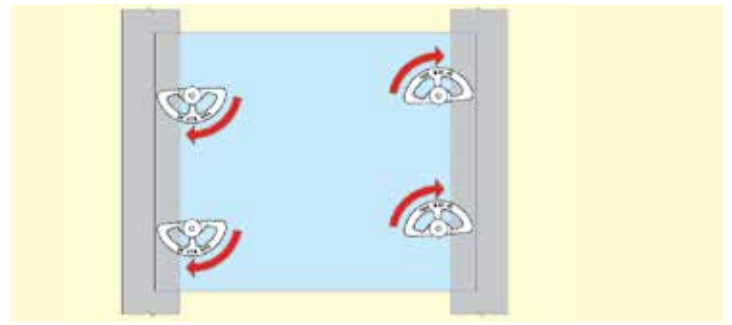

**Step 4** Tighten the countersunk screw until the plate is secured, for guaranteed performance use the recommended tightening torques given in the table on page 41.

**Note 2** If the steelwork being connected to is thicker than 25mm then we can supply packers and a longer bolt to increase the fixing range.

## FloorFix

- Installation from one side only
- Manufactured from Ductile Iron
- Hot Dip Galvanised
- Allows for easy maintenance

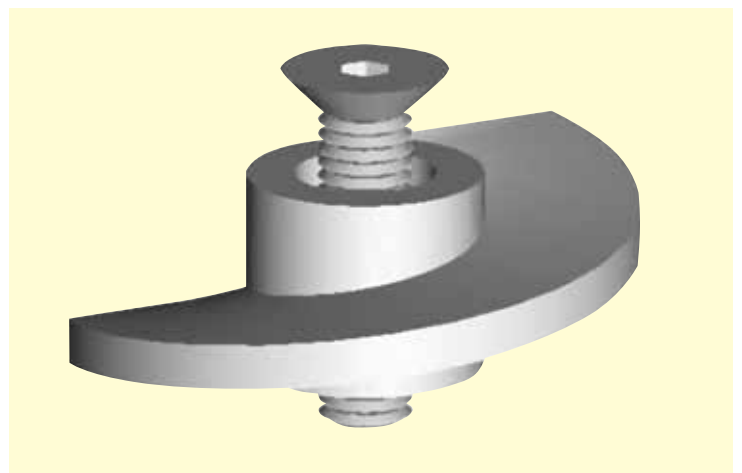
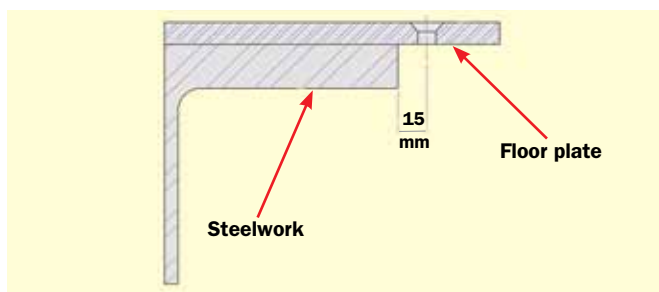

Product Code	Screw Diameter	Floor Plate Thickness		Steelwork Flange Thickness		Tightening Torque (Nm)
		min	max	min	max	
FloorFix M08	M08	3	12	3	15	20
FloorFix M10	M10	5	12	3	15	25
FloorFix M12	M12	6	12	3	15	30

## FloorFix HT to Connect Plate Flooring on the Top of a Mezzanine Floor



The **FLOORFIX HT** (High Tolerance) was used to secure the chequer plate flooring onto to the supporting steelwork from the top side only requiring no access to the underside and no need to drill or weld the supporting structure. The **FLOORFIX HT** allows for steel erection tolerances of plus and minus 6mm without compromising the integrity of the fixing.

# Gratefix

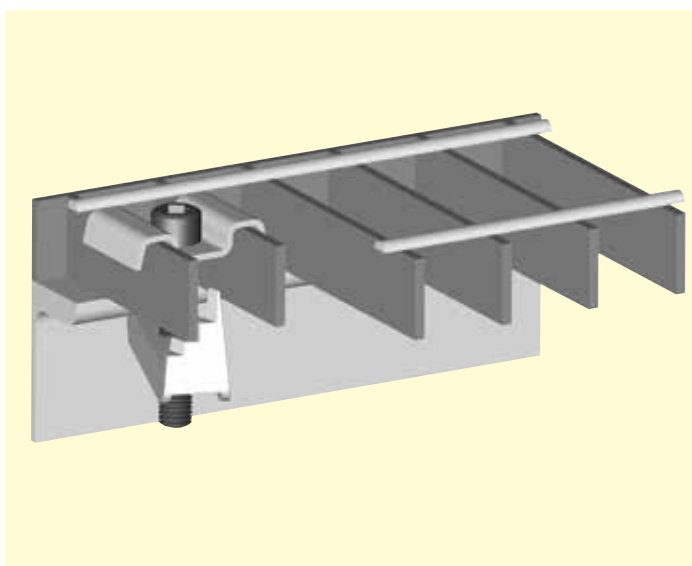

- **Mechanical Galvanised Malleable Iron**
- **Stainless Steel Grade 304**
- **Easily installed from the top side only**
- **No drilling, no tapping or welding required**
- **Allows easy repositioning or lifting of grating**
- **No special tools or skilled labour required**
- **No access to the underside required**
- **Tested for vibration conditions at TÜV**

**THE GRATEFIX** is a heavy-duty fixing that allows open floor grating to be fixed to the supporting steelwork from the topside only. **The Gratefix** features a cast bottom piece that provides additional strength to clamp on to the steelwork flange. The Gratefix is available in several different styles to suit the grating dimensions and the application. A mechanical galvanised **M10** version is available with a symmetrical top bracket to suit **30mm ctrs** grating or with an offset bracket to suit **30-41mm ctrs** grating most commonly found in the UK. The **M08** version is also available in grade **304** stainless steel with a top bracket to suit **30mm ctrs**.

## Option 1

**Pressed Top Bracket – Stainless Steel to EN 10088 Grade 1.4301 (AISI 304)**

**Cast Bottom Bracket – Stainless Steel to ASTM A743 Grade CF-8 (S30400)**

## Option 2

**Pressed Top bracket – Material: Mild steel to EN 10025 grade S275**

**Cast Bottom Bracket – Material: Malleable iron to BS 1562: Grade EN-GJMB-300-06**

**Both finished in: Mechanical Galv to ASTM B695**

Product code	Material/Finish	Screw dia	To suit Grating Bar centres	To suit Grating Bar depths (mm)	Tightening torque (Nm)
<b>GF3 S08 ASSY</b>	Option 1	M08	30mm	50	8
<b>GF1 G10 ASSY</b>	Option 2	M10	30 to 41mm	50	5

## Installation

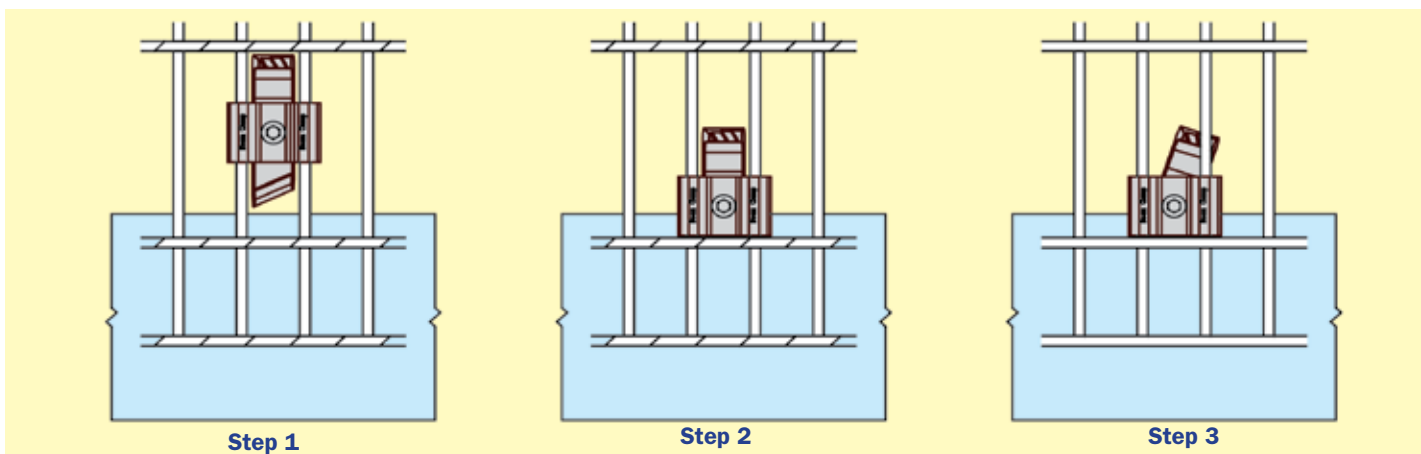

# Grating Clip

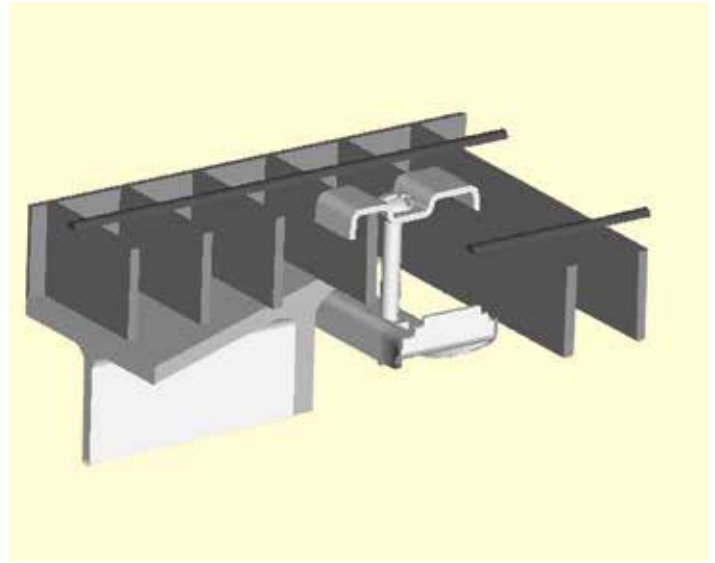
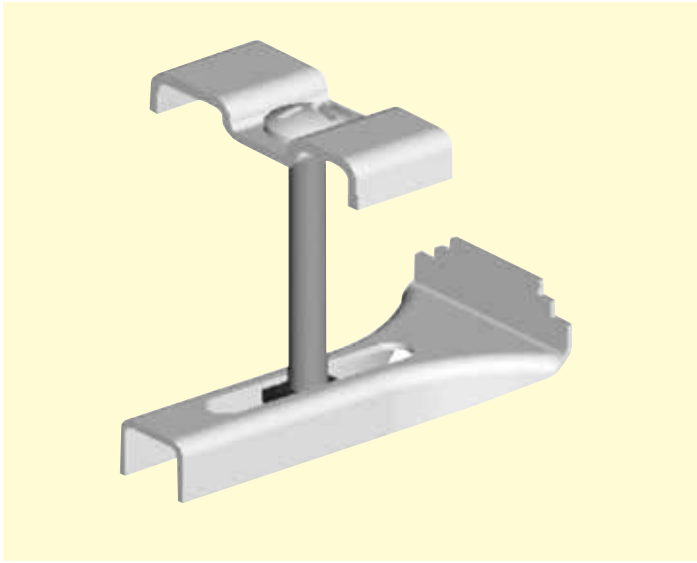

**THE GRATING CLIP** is the most common style of clip used for fixing down open steel flooring in the UK. It provides a quick and cost effective method of fixing. It is **Hot Dip Galvanised** and comes as standard with a top bracket to suit **30-41mm ctrs grating bars**.

Product code	Screw dia	Grating width		Grating depth Maximum	Tightening torque (Nm)
		min	max		
GRAT1G08	M08	30	41	50	8

# Testing

As previously mentioned the **Floorfix HT**, **FloorFix** and **Gratefix** have been tested in conditions to simulate the typical applications of these fixings. The fixings were tested for performance in both

vertical and horizontal axis to ensure they did not work loose when subjected to vibration conditions. The test set-up can be seen below, the certificates are available on request.



**Horizontal Axis Test**



**Vertical Axis Test**



# BeamClamp® BL Flange Clamp

The **BL** Flange Clamp is a clamping system that is used for the suspension of threaded bar to support building services such as cable trays, HVAC systems and lighting. The BL can be supplied as an assembly with a bolt and nut or as a two piece clamp where the user can install their own central threaded product.

The BL Flange Clamp is commonly used with threaded bar as shown on the diagram below but it can be used with other threaded items such as eyebolts or J-Bolts. The BL can also be used with brackets underneath the washer/nut and has been tested for backwards pull off loads to allow it to be used in this condition.

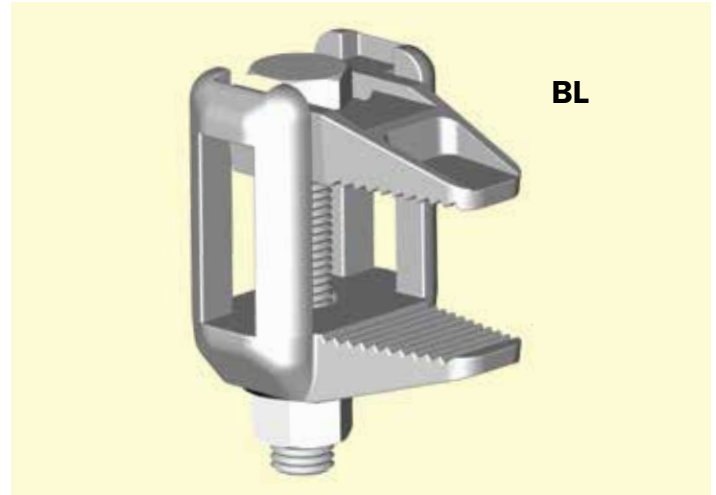

- Only requires one tool for installation
- Hot Dip Galvanised to BS EN ISO 1461
- Extensive fixing range

- Can accommodate clips/brackets
- Tested for Tensile and Lateral Loading

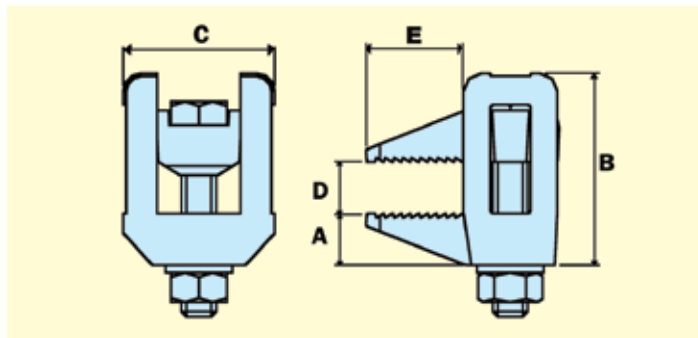

The Safe Working Loads are based on assemblies tested in typical conditions

3 to 1 Factor of safety applied

Product Code	A (mm)	B (mm)	C (mm)	D (mm)	E (mm)	Tightening torque (Nm)	Tensile load in line with rod (kN)	Tensile load at nose (kN) (per pair)	Lateral load (kN)
BLG08A	12.5	45	40	5 to 20	24	10	1.0	7.4	0.25
BLG10A	14	58	47	6 to 30	30	20	2.5	9.3	0.40
BLG12A	15	65	51.5	7 to 35	34	40	5.0	11.0	0.60
BLG16A	20	95	58	8 to 55	44	90	7.5	20.3	0.70
BLG20A	23	116	66	8.5 to 70	53	180	9.0	23.3	0.75
BLG24A	26	147	75	9 to 95	62	200	10.5	34.3	0.80

Do not exceed the Safe Working Load (SWL) specified

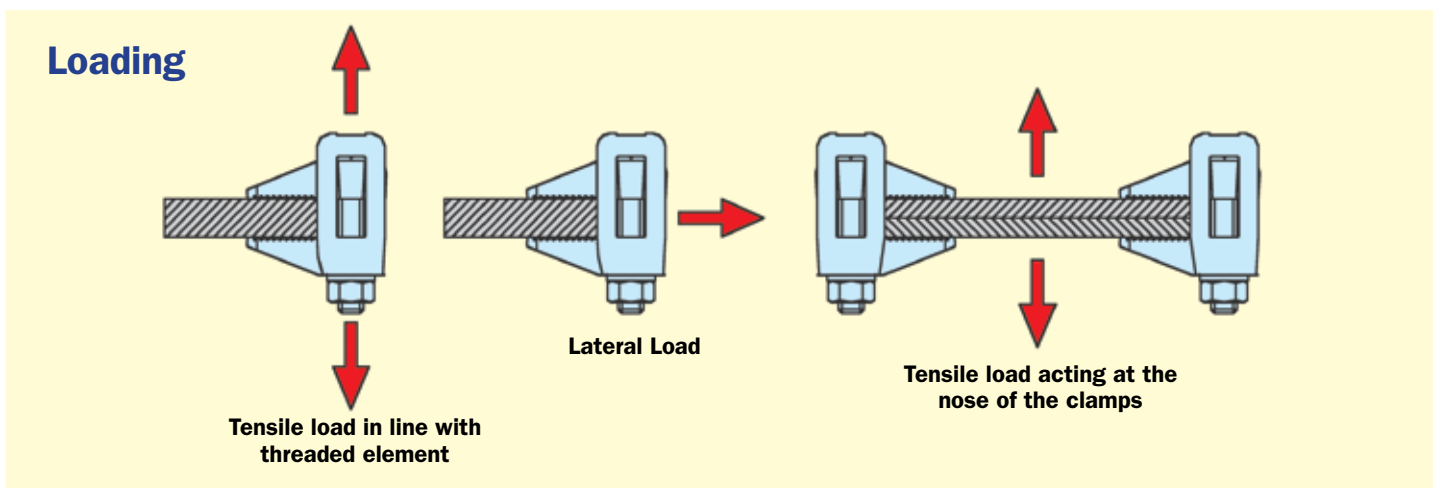

# Building Services Fixings

## Hemispherical Cups and Washers - BV1 & BU1

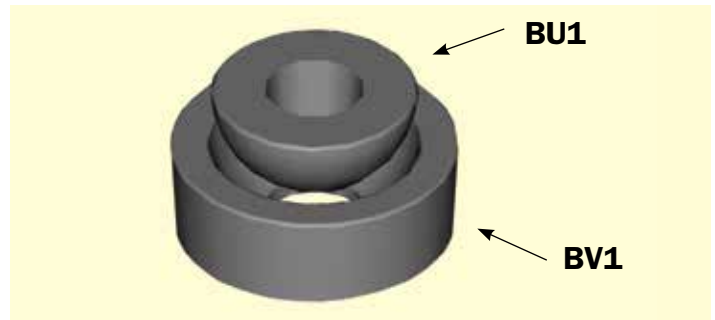
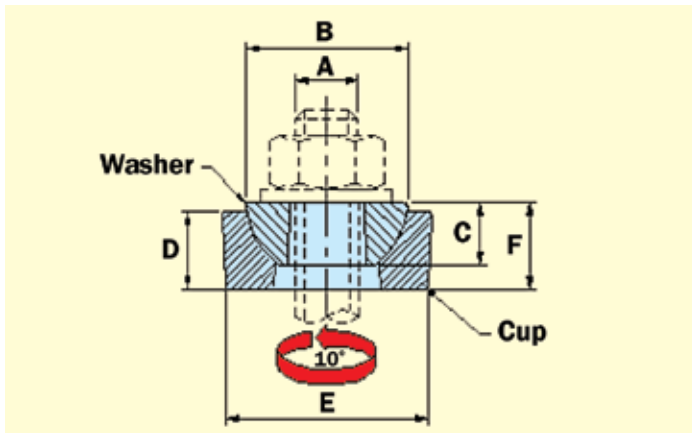

The hemispherical washers (**BU1**) and cups (**BV1**) provide a pivotable action when used with threaded bar. They allow a 10 degree swing in all directions from vertical and when used in pairs can provide a locked connection as shown on page 48. Typical applications would be connecting to a roof rafter where the threaded bar needs to be hanging perpendicular to the floor or for making a ball socket on the legs of air conditioning support frames to allow adjustability for sloping roofs.

- Allows a swing of 10° in all directions
- Prevents the need to bend threaded bar
- Provides pivotable element for adjustment

Washer part code	Cup part code	A Bolt dia	B (mm)	C (mm)	D (mm)	E (mm)	F (mm)	Tensile load (kN)
BU1G08	n/a	8	22	8	n/a	n/a	n/a	1.25
BU1G10	BV1G10	10	25	10	12	32	14	2.5
BU1G12	BV1G12	12	29	12	12	35	14	4.12
BU1G16	BV1G16	16	34	14	16	41	19	6.6
BU1G20	BV1G20	20	44	19	20	54	23.5	9.57
BU1G24	BV1G24	24	57	24	25	67	29	12.75

All of the above loads have been subject to a 5:1 Factor of Safety.

## Vee Nuts - BX1

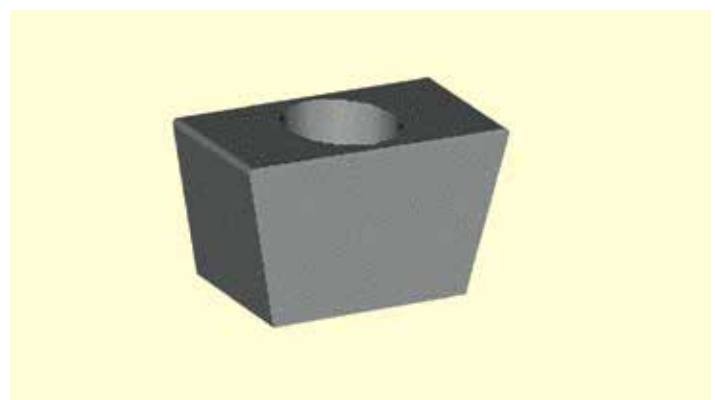
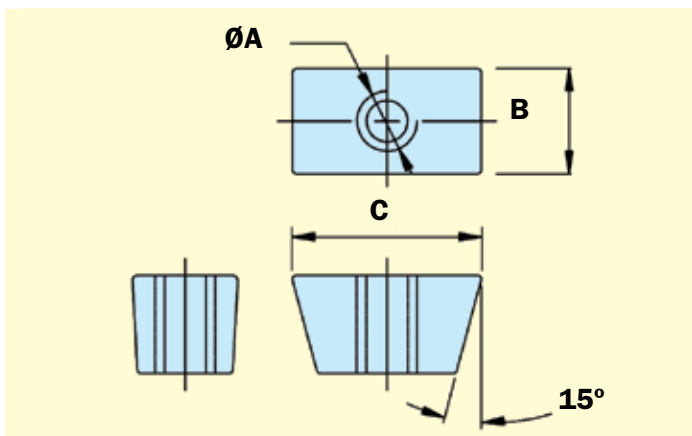

- M06, M08 and M10 tapped holes
- Allows easy fixing to decking
- No penetration of the deck required

Part code	A Bolt dia	B (mm)	C (mm)	Tensile load (kN)
BX1Z06	M06	13	25	2.4
BX1Z08	M08	13	25	2.4
BX1Z10	M10	13	25	2.4

All of the above loads have been subject to a 3:1 Factor of Safety.

**Vee nuts** have tapered sides at 15° to fit in to the re-entrant channels of metal decking. They are used for fixing light duty building services equipment to the underside of the decking profile.

# Suspension Fixings - Applications



Hemispherical cup/washer hanging an I-Section underneath a sloping section

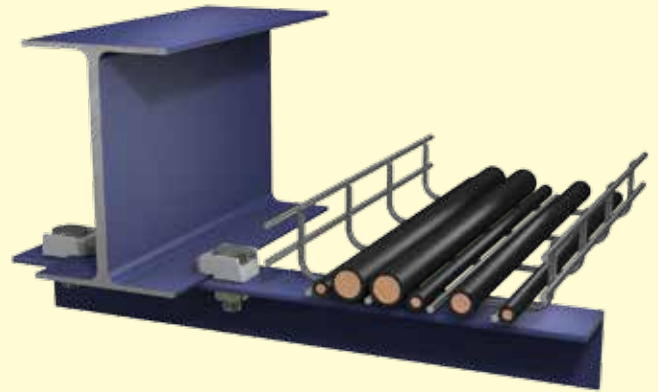

Cantilevered angle support for running cable tray

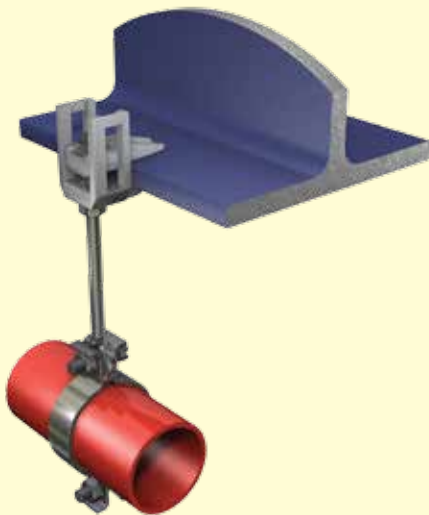

BL Flange clamp with pipe clip and threaded bar hanging pipework

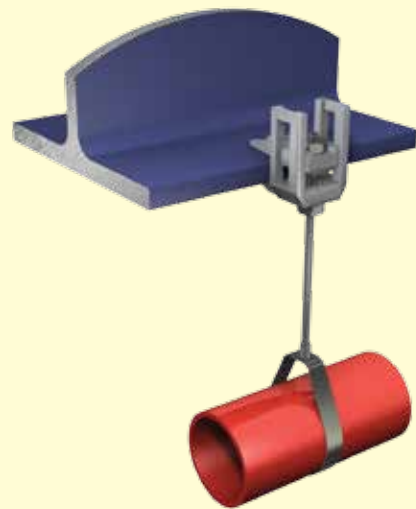

BL Flange clamp with strap hanger and threaded bar hanging pipework

## Uni-Wedge® - BN2

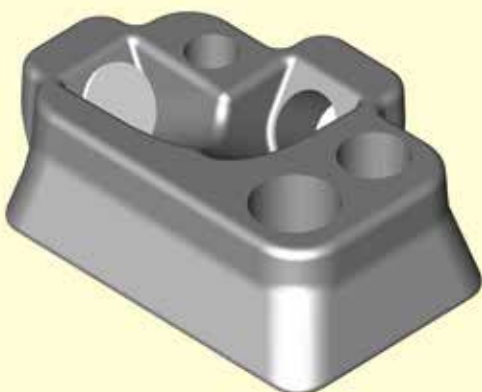

- One fixing suits seven most popular decking profiles
- Allows for manufacturing tolerances in the deck profile
- Single piece construction
- Separate fixing screw to ease final adjustment
- M06, M08 & M10 threaded fixing holes
- Requires no site power or skilled labour
- Tested at the British Board of Agrément

# Uni-Wedge® - BN2

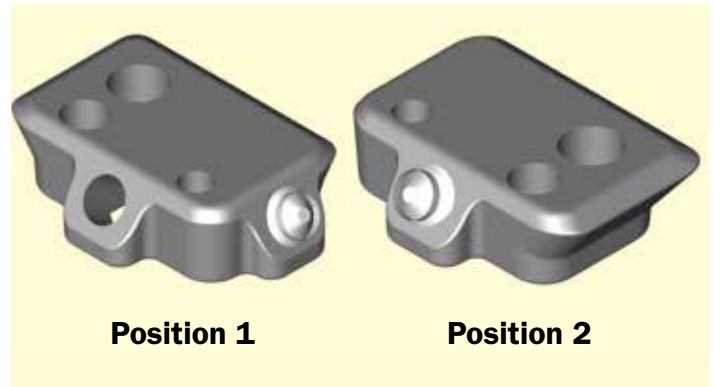
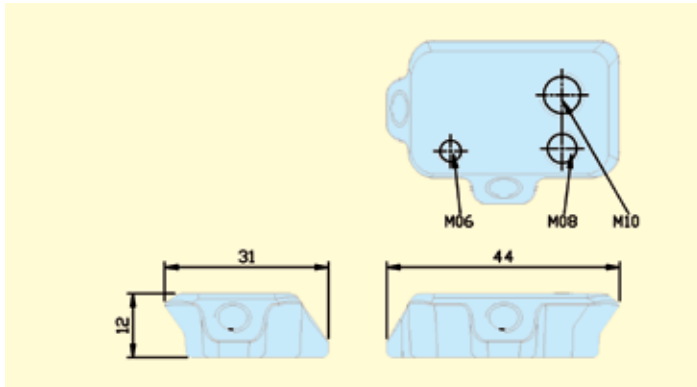

**Uni-Wedge** has been specifically designed as a single universal fixing suitable for the seven most popular deck profiles available in the UK. These decking profiles are nearly always present on steel constructed multi-storey buildings and **Uni-Wedge** provides a solution to fix building services equipment without penetrating the decking membrane. This fixing provides a guaranteed safe working load and simply requires a standard hexagon key and spanner with no requirement for power, special tools or highly skilled labour. **Uni-Wedge** has a unique body style that allows it to fix to seven decking profiles, making it easy to use and specify. The specific type of decking is not always easy to

identify on site and has caused installers problems when trying to acquire the correct fixing to use, but **Uni-Wedge** provides the ideal solution (see table below). **Uni-Wedge** has been designed for the end user to ensure that whatever the situation the right connection can be made as quickly as possible. **Uni-Wedge** has a fixing screw that is assembled in the body and provides a positive location in the decking re-entrant channel. This screw is assembled as standard in position 1 but can easily be removed and placed in to position 2 to suit the other decking profiles, see table below:

Decking Manufacturer	Decking type	Screw position	M06, M08 & M10	Tightening torque (Nm)
			Tensile SWL (kN) (3 to 1 Factor of safety)	Use 4mm Hexagon key to tighten grub screw
<b>KINGSPAN</b>	Multi deck 60 - V2	1	1.0	8
	Multi deck 80 - V2	1	1.0	8
<b>HARE DECKING</b>	Rib deck 80	1	1.0	8
	Rib deck AL	1	1.0	8
	Rib deck E60	1	1.0	8
<b>SMD</b>	TR60	2	1.0	8
	TR80	2	1.0	8

### IMPORTANT!

- Only use one threaded bar per fixing
- The decking must not be damaged and have a fully formed re-entrant channel
- Ensure the cone point grub screw is fully engaged into the corner of the re-entrant channel
- Do not screw the threaded bar any further in than the top surface of the fixing
- Ensure the fixing is a minimum 300mm from any edges of the decking

**FINISH:** Zinc Plated to BS EN 12329:2000 Grade Fe//Zn5//A (Clear)

**MATERIAL:** SG (Ductile) Iron to BS EN 1563 Grade EN-GJS-450-10

## Uni-Wedge® Installation Steps



**1.** Select the correct position for the grub screw to suit decking profile as shown on the left Position 1 or 2.



**2.** Insert **Uni-Wedge** in to the re-entrant channel of the deck. Ensure the point of the grub screw is not exposed at the top of the hole as this will stop **Uni-Wedge** fitting.



**3.** Tighten the grub screw to secure the fixing. We recommend a tightening torque of 8Nm to achieve a guaranteed SWL.

**4.** Once the grub screw is secured one of the **M06, M08 or M10** threaded holes can be fixed to. This maybe threaded bar, eyebolts, J-bolts or any other threaded items used for suspending building services. We always recommend the threaded item is locked in to position using a lock nut to the underside of **Uni-Wedge**.

## Uni-Wedge® Applications

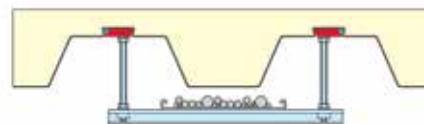

**Strut support for cable tray**



**Suspended ceiling detail using hook bolts**

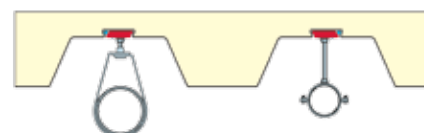

**Typical pipe supports**



# Steelwork Dimensions

These two pages are designed to give a quick reference to the most important dimensions of the steelwork required for making a **BeamClamp** connection.

All the dimensions given for 't' are based on the dimension at the edge of the steel flange, even for tapered steelwork as this is the critical dimension.

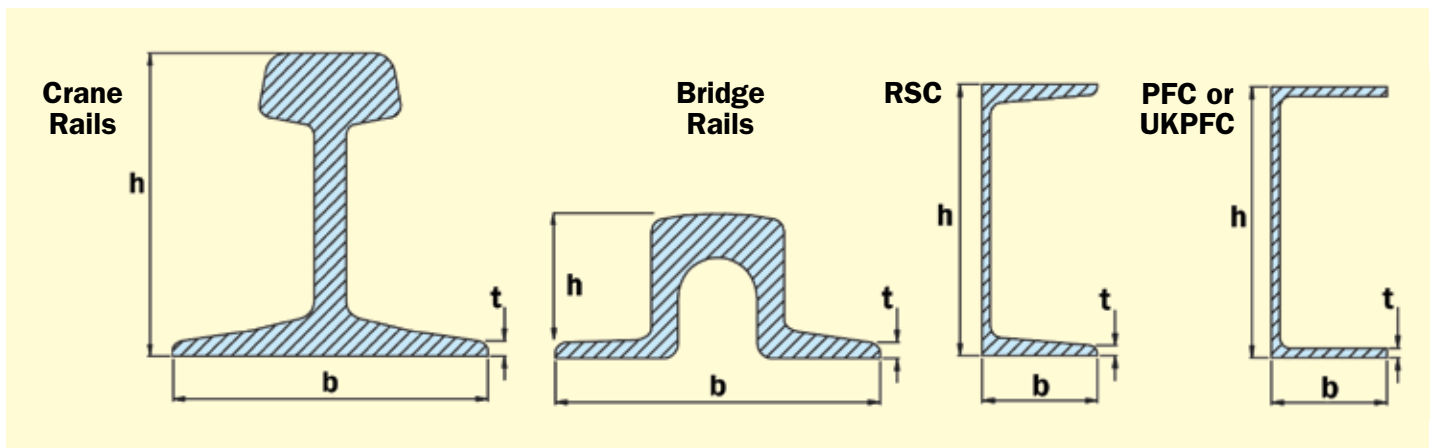
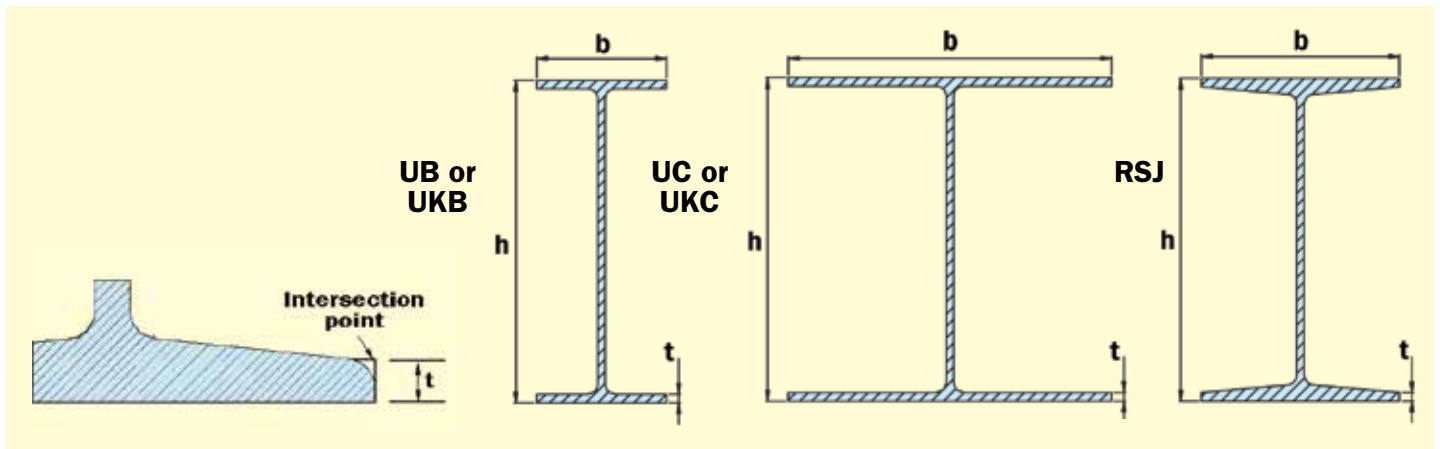

## UB / UKB - Universal Beams

Designation	Weight (kg/m)	h (mm)	b (mm)	t (mm)
1016x305x487	487	1036.1	308.5	54.1
1016x305x438	438	1025.9	305.4	49
1016x305x393	393	1016	303	43.9
1016x305x349	349	1008.1	302	40
1016x305x314	314	1000	300	35.9
1016x305x272	272	990.1	300	31
1016x305x249	249	980.2	300	26
1016x305x222	222	970.3	300	21.1
914x419x388	388	921	420.5	36.6
914x419x343	343	911.8	418.5	32
914x305x289	289	926.6	307.7	32
914x305x253	253	918.4	305.5	27.9
914x305x224	224	910.4	304.1	23.9
914x305x201	201	903	303.3	20.2
838x292x226	226	850.9	293.8	26.8
838x292x194	194	840.7	292.4	21.7
838x292x176	176	834.9	291.7	18.8
762x267x197	197	769.8	268	25.4
762x267x173	173	762.2	266.7	21.6
762x267x147	147	754	265.2	17.5
762x267x134	134	750	264.4	15.5
686x254x170	170	692.9	255.8	23.7
686x254x152	152	687.5	254.5	21
686x254x140	140	683.5	253.7	19
686x254x125	125	677.9	253	16.2
610x305x238	238	635.8	311.4	31.4
610x305x179	179	620.2	307.1	23.6

Designation	Weight (kg/m)	h (mm)	b (mm)	t (mm)
610x305x149	149	612.4	304.8	19.7
610x229x140	140	617.2	230.2	22.1
610x229x125	125	612.2	229	19.6
610x229x113	113	607.6	228.2	17.3
610x229x101	101	602.6	227.6	14.8
533x210x122	122	544.5	211.9	21.3
533x210x109	109	539.5	210.8	18.8
533x210x101	101	536.7	210	17.4
533x210x92	92	533.1	209.3	15.6
533x210x82	82	528.3	208.8	13.2
457x191x98	98	467.2	192.8	19.6
457x191x89	89	463.4	191.9	17.7
457x191x82	82	460	191.3	16
457x191x74	74	457	190.4	14.5
457x191x67	67	453.4	189.9	12.7
457x152x82	82	465.8	155.3	18.9
457x152x74	74	462	154.4	17
457x152x67	67	458	153.8	15
457x152x60	60	454.6	152.9	13.3
457x152x52	52	449.8	152.4	10.9
406x178x74	74	412.8	179.5	16
406x178x67	67	409.4	178.8	14.3
406x178x60	60	406.4	177.9	12.8
406x178x54	54	402.6	177.7	10.9
406x140x46	46	403.2	142.2	11.2
406x140x39	39	398	141.8	8.6
356x171x67	67	363.4	173.2	15.7

Designation	Weight (kg/m)	h (mm)	b (mm)	t (mm)
356x171x57	57	358	172.2	13
356x171x51	51	355	171.5	11.5
356x171x45	45	351.4	171.1	9.7
356x127x39	39	353.4	126	10.7
356x127x33	33	349	125.4	8.5
305x165x54	54	310.4	166.9	13.7
305x165x46	46	306.6	165.7	11.8
305x165x40	40	303.4	165	10.2
305x127x48	48	311	125.3	14
305x127x42	42	307.2	124.3	12.1
305x127x37	37	304.4	123.3	10.7
305x102x33	33	312.7	102.4	10.8
305x102x28	28	308.7	101.8	8.8
305x102x25	25	305.1	101.6	7
254x146x43	43	259.6	147.3	12.7
254x146x37	37	256	146.4	10.9
254x146x31	31	251.4	146.1	8.6
254x102x28	28	260.4	102.2	10
254x102x25	25	257.2	101.9	8.4
254x102x22	22	254	101.6	6.8
203x133x30	30	206.8	133.9	9.6
203x133x25	25	203.2	133.2	7.8
203x102x23	23	203.2	101.8	9.3
178x102x19	19	177.8	101.2	7.9
152x89x16	16	152.4	88.7	7.7
127x76x13	13	127	76	7.6

# Steelwork Dimensions

## UC / UKC - Universal Columns

Designation	Weight (kg/m)	h (mm)	b (mm)	t (mm)
356x406x634	634	474.7	424.1	77
356x406x551	551	455.7	418.5	67.5
356x406x467	467	436.6	412.4	58
356x406x393	393	419.1	407	49.2
356x406x340	340	406.4	403	42.9
356x406x287	287	393.7	399	36.5
356x406x235	235	381	394.8	30.2
356x368x202	202	374.4	374.7	27
356x368x177	177	368.3	372.1	23.8
356x368x153	153	362	370.2	20.7
356x368x129	129	355.6	368.3	17.5

Designation	Weight (kg/m)	h (mm)	b (mm)	t (mm)
305x305x283	283	365.3	322.2	44.1
305x305x240	240	352.5	318.4	37.7
305x305x198	198	339.9	314.5	31.4
305x305x158	158	327.1	311.2	25
305x305x137	137	320.5	309.2	21.7
305x305x118	118	314.5	307.4	18.7
305x305x97	97	307.9	305.3	15.4
254x254x167	167	289.1	265.2	31.7
254x254x132	132	276.3	261.3	25.3
254x254x107	107	266.7	258.8	20.5
254x254x89	89	260.3	256.3	17.3

Designation	Weight (kg/m)	h (mm)	b (mm)	t (mm)
254x254x73	73	254.1	254.6	14.2
203x203x86	86	222.2	209.1	20.5
203x203x71	71	215.8	206.4	17.3
203x203x60	60	209.6	205.8	14.2
203x203x52	52	206.2	204.3	12.5
203x203x46	46	203.2	203.6	11
152x152x37	37	161.8	154.4	11.5
152x152x30	30	157.6	152.9	9.4
152x152x23	23	152.4	152.2	6.8

## RSJ - Rolled Steel Joists

Type	Weight (kg/m)	h (mm)	b (mm)	t (mm)
254x203x82	82	254	203.2	12.7
203x152x52	52	203.2	152.4	12.7
152x127x37	37	152.4	127	9.5

Type	Weight (kg/m)	h (mm)	b (mm)	t (mm)
89x89x19	19	88.9	88.9	8.4
76x76x13	13	76.2	76.2	6.3

Type	Weight (kg/m)	h (mm)	b (mm)	t (mm)
127x114x29	29	127	114.3	9.5
127x114x27	27	127	114.3	9.5
102x102x23	23	101.6	101.6	8.5

## RSC - Rolled Steel Channels

Designation	Weight (kg/m)	h (mm)	b (mm)	t (mm)
432x102x65	65	431.8	101.6	14.5
381x102x55	55	381	101.6	12.7
305x102x46	46	304.8	101.6	11.1
305x89x42	42	304.8	88.9	11.1
254x89x36	36	254	88.9	11.1

Designation	Weight (kg/m)	h (mm)	b (mm)	t (mm)
254x76x28	28	254	76.2	8
229x89x33	33	228.6	88.9	9.5
229x76x26	26	228.6	76.2	8
203x89x30	30	203.2	88.9	9.5
203x76x24	24	203.2	76.2	8

Designation	Weight (kg/m)	h (mm)	b (mm)	t (mm)
178x89x27	27	177.8	88.9	9.5
178x76x21	21	177.8	76.2	8
152x89x24	24	152.4	88.9	8
152x76x18	18	152.4	76.2	6
127x64x15	15	127	63.5	8

## PFC / UKPFC - Parallel Flanged Channel

Designation	Weight (kg/m)	h (mm)	b (mm)	t (mm)
430x100x64	64	430	100	19
380x100x54	54	380	100	17.5
300x100x46	46	300	100	16.5
300x90x41	41	300	90	15.5
260x90x35	35	260	90	14
260x75x28	28	260	75	12

Designation	Weight (kg/m)	h (mm)	b (mm)	tf (mm)
230x90x32	32	230	90	14
230x75x26	26	230	75	12.5
200x90x30	30	200	90	14
200x75x23	23	200	75	12.5
180x90x26	26	180	90	12.5
180x75x20	20	180	75	10.5

Designation	Weight (kg/m)	h (mm)	b (mm)	t (mm)
150x90x24	24	150	90	12
150x75x18	18	150	75	10
125x65x15	15	125	65	9.5
100x50x10	10	100	50	8.5

## Crane Rails

Designation	Weight (kg/m)	h (mm)	b (mm)	f (mm)
BS 20 M	9.88	65.09	55.56	5.4
BS 30 M	14.79	75.41	69.85	6.4
BS 35 M	17.39	80.96	76.2	5.9
BS 35 R	17.4	85.73	82.55	5.8
BS 40	19.89	88.11	80.57	5
BS 50 O	24.82	100.01	100.01	7.1
BS 60 A	30.62	114.3	109.54	7.54
BS 60 R	29.85	114.3	109.54	7.54
BS 70 A	34.81	123.82	111.12	7.94
BS 75 A	37.45	128.59	114.3	8.33
BS 75 R	37.09	128.59	122.24	8.33
BS 80 A	39.76	133.35	117.47	8.73

Designation	Weight (kg/m)	h (mm)	b (mm)	f (mm)
BS 80 O	39.74	127	127	10.3
BS 80 R	39.72	133.35	127	8.7
BS 90 A	45.1	142.88	127	9.13
BS 90 R	44.58	142.88	136.53	9.13
BS 95 A	47.31	147.64	130.17	9.13
BS 95 N	47.27	147.64	139.7	9.13
BS 95 R	47.21	147.64	141.29	9.13
BS 100 A	50.18	152.4	133.35	9.52
BS 100 R	49.6	152.4	146.05	10
BS 110 A	54.52	158.75	139.7	11.11
BS 113A	56.22	158.75	139.7	11.11
BS 56	56.81	101.5	171	10

Designation	Weight (kg/m)	h (mm)	b (mm)	f (mm)
BSC 89	88.93	114	178	16
BSC 101	100.4	155	165	18
BSC 164	166	150	230	32
A45	22.1	55	125	8
A55	31.8	65	150	9
A65	43.1	75	175	10
A75	56.2	85	200	11
A100	74.3	95	200	12
A120	100	105	220	14
A150	150.3	150	220	14

## Bridge Rails

Designation	Weight (kg/m)	h (mm)	b (mm)	f (mm)
BS 13	13.31	48	92	8.5
BS 16	16.06	54	108	8

Designation	Weight (kg/m)	h (mm)	b (mm)	f (mm)
BS 20	19.86	55.5	127	8.5
BS 28	28.62	67	152	10

Designation	Weight (kg/m)	h (mm)	b (mm)	f (mm)
BS 35	35.38	76	160	10.5
BS 50	50.18	76	165	15



Kee Safety Limited  
Cradley Business Park  
Overend Road Cradley Heath  
West Midlands  
B64 7DW United Kingdom

Tel: +44 (0) 1384 632188

Fax: +44 (0) 1384 632192

Email: [sales@keesafety.com](mailto:sales@keesafety.com)

[www.keesafety.co.uk](http://www.keesafety.co.uk)